



We care about your success

Catálogo Técnico
Technical catalogue **2020**

Refrigeradores y Congeladores biomédicos para farmacias y laboratorios
Biomedical, pharmaceutical and laboratory Refrigerators and Freezers



We care about your samples

We care about your reagents

We care about your operating expenses

We care about the environment

We care about our quality

We care about all the details

We care about your satisfaction

We care about your success...

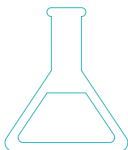

ÍNDICE / TABLE OF CONTENTS

	<p> 04 INFRICO MEDCARE - La Empresa / The Company</p>	
	<p> 18 PHARMA CARE</p> <p>20 Gama Pharma Care / Pharma Care Series DIN 58345</p> <p>20 Gama Pharma Care Plus / Pharma Care Plus Series DIN 58345</p> <p>22 Características Generales / General Features</p> <p>26 Fichas Técnicas de Productos / Technical Product Data</p>	PHARMA 1
	<p> 34 HEALTH CARE</p> <p>36 Gama Health Care Plus / Health Care Plus Series DIN 58371</p> <p>40 Características Generales / General Features</p> <p>44 Fichas Técnicas de Productos / Technical Product Data</p>	HEALTH 2
	<p> 48 LAB CARE</p> <p>50 Gama Lab Care Refrigeración / Lab Care Refrigeration Series</p> <p>51 Gama Lab Care Congelación / Lab Care Freezer Series</p> <p>51 Gama Lab Care Plus Congelación / Lab Care Plus Freezer Series</p> <p>54 Características Generales / General Features</p> <p>58 Fichas Técnicas de Productos / Technical Product Data</p>	LAB 3
	<p> 86 EQUIPAMIENTO OPCIONAL / OPTIONAL EQUIPMENT</p>	4
	<p> 90 EQUIPAMIENTO COMPLEMENTARIO / COMPLEMENTARY EQUIPMENT</p> <p>92 Cámaras Frigoríficas Modulares / Modular Cold Rooms</p> <p>96 Estanterías Modulares / Modular Shelving System</p> <p>98 Arcones Congeladores / Chest Freezers</p> <p>99 Máquinas de Hielo Troceado / Crushed Ice Makers</p> <p>100 Lavado / Washing Machines</p>	5
<p> 106 SOLUCIONES A MEDIDA / CUSTOMISED SOLUTIONS</p>	6	
<p> 108 SERVICIO DE ATENCIÓN AL CLIENTE / CUSTOMER SERVICE</p>	7	
<p> 110 SELECCIÓN DE PRODUCTO / PRODUCT SELECTION</p> <p>110 Tabla de Características Generales / General Features Chart</p> <p>111 Tabla de Selección de Producto / Product Selection Chart</p>	8	



FÁBRICA / FACTORY

INFRICO Medicare nace con un claro objetivo de exportar nuestra experiencia en refrigeración al sector sanitario, presentando la nueva línea de productos específicos y adaptados para laboratorios, bancos de sangre y farmacias. Vanguardia tecnológica y calidad certificada son las garantías que avalan el compromiso de nuestra fabricación: **generar las mejores ideas y soluciones para los clientes más exigentes.**

Existe una gran diferencia entre los equipos de refrigeración para canal HORECA y para sector médico o de laboratorios. Por este motivo, Infrico ha dedicado varios años de investigación de un grupo humano altamente cualificado para obtener las correspondientes certificaciones.

La seguridad de nuestros equipos es lo más importante, dado que están destinados al almacenamiento de muestras de gran valor. Por ello nuestro propósito es satisfacer estrictos requisitos de temperatura para garantizar la adecuada conservación de las mismas.

El Centro de Producción Infrico es una de las instalaciones industriales más modernas de España. La planta cuenta con una superficie total de 40.000 metros cuadrados dedicados a producción y una extensión de 60.000 metros cuadrados para actividades logísticas. Un esfuerzo inversor que complementa a la incorporación de tecnología de vanguardia, para ofrecer las mejores soluciones en frío.



INFRICO Medicare was born with a clear objective to share our experience in refrigeration to the healthcare sector, presenting the new line of specific products adapted for laboratories, blood banks and pharmacies. Forefront technology and certified quality are our guarantees that vouch for our commitment to Infrico Medicare production: **generating the best ideas and solutions for the most demanding clients.**

There is a big difference between the refrigeration equipment for the hotel / restaurants sector and the laboratories / healthcare sector. For this reason, Infrico has dedicated several years of investigation of highly qualified human resources to obtain the corresponding certifications.

The security of our equipment is of utmost importance because it is made to store very important and delicate samples. Therefore, our aim is to satisfy strict temperature requirements, to guarantee the correct conservation of the samples.

The Infrico's Production Centre is one of the most modern industrial installations in Spain. The plant has a total surface of 40,000 square metres dedicated to production and an extension of 60,000 square metres for logistic activities. An investment effort that compliments the incorporation of the latest technology to offer the best solutions in cooling equipment.





MISIÓN / THE MISSION

Nuestra misión consiste en ser el **primer fabricante español de equipos de frío para productos sensibles**, garantizando la máxima calidad de toda nuestra gama y a la vez la completa tranquilidad a todos nuestros usuarios.

Infrico Medicare tiene como su principal objetivo cuidar hasta el mínimo detalle y facilitar el trabajo diario en todo tipo de laboratorios, bancos de sangre y farmacias. Gracias a la continua inversión en nuestro I+D, podemos ofrecer una amplia gama de producto específico para el sector y soluciones personalizadas únicas.

Cuidamos nuestra calidad...
We care about our quality...

Our mission is to be **the first Spanish manufacturer of cooling equipment for sensitive products**, guaranteeing a high quality of our entire range and at the same time complete peace of mind for all our users.

Infrico Medcare has as its main goal to take care of every detail and facilitate daily work in all types of laboratories, blood banks and pharmacies. Thanks to continuous investment in our R&D, we can offer a wide range of specific products for this sector and unique customised solutions.

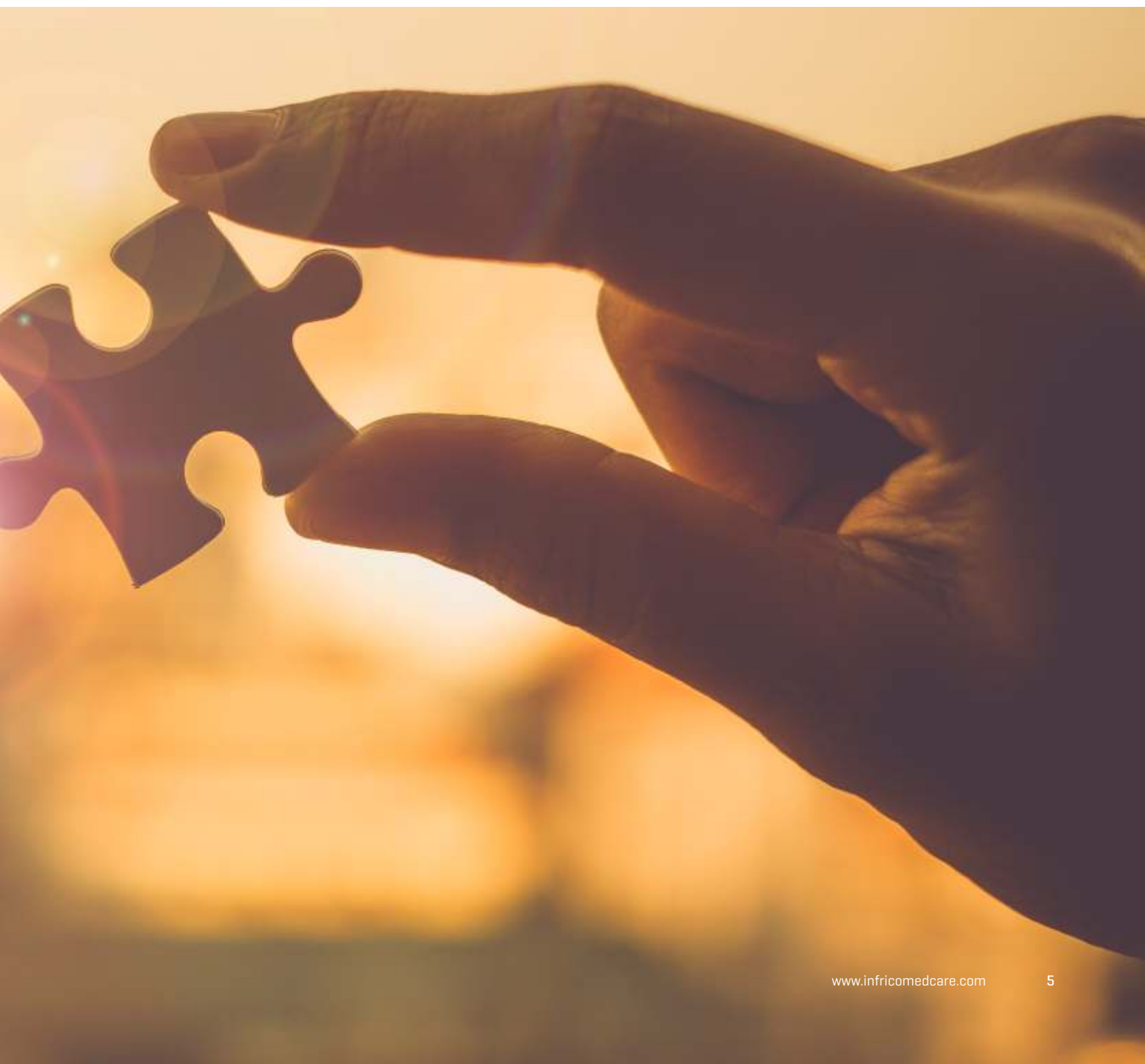



Cuidamos todos
los detalles...

We care about
all the details...



NUESTRO COMPROMISO / OUR COMMITMENTS



Nuestro compromiso con los clientes

Our commitment to our clients



Un trabajo orientado siempre a la satisfacción del usuario final. Diseño y tecnología de vanguardia para ofrecer total seguridad y la máxima calidad. Confianza, seriedad y profesionalidad en la relación con proveedores y clientes: un servicio postventa y asistencia técnica de alto nivel, puntual y eficaz.

Our work is always oriented towards the individual, so that the final user experiences full satisfaction. Cutting edge design and technology to offer total security and maximum quality. Confidence, seriousness and professionalism in relation to the suppliers and clients: a high level post-sale service and efficient and punctual technical support.



Nuestro compromiso con la innovación

Our commitment to innovation



Las buenas ideas son la clave del éxito. La compañía realiza un constante esfuerzo en innovación y mejora de la calidad, una apuesta que ha sido certificada y reconocida con distintos premios internacionales.

Good ideas are the key to success. The company is constantly making an effort to innovate and improve quality, a commitment that has been certified and recognised with distinctions and international prizes.



Nuestro compromiso con la sociedad

Our commitment to society



Infrico Medcare es consciente de su responsabilidad social como agente económico y de desarrollo: riqueza, difusión de conocimientos y experiencias, proyectos de desarrollo e innovación, son algunos de los compromisos que Infrico tiene con la sociedad.

Infrico is aware of its social responsibility as an economic and development agent: employment, wealth, sharing of knowledge and experience, development and innovation projects are some of the commitments that Infrico has to society.



Nuestro compromiso con el medioambiente

Our commitment to the environment



En el trabajo diario, además de responder a las necesidades de sus clientes, Infrico Medcare presta especial atención a las iniciativas que contribuyan al desarrollo de una industria sostenible y respetuosa con el medioambiente, mediante una correcta administración de los recursos naturales, el adecuado tratamiento de los residuos, así como el reciclaje y la reutilización de los materiales.

In our daily work, besides responding to the needs of our clients, Infrico pays special attention to the initiatives that contribute to the development of a respectful and sustainable industry within the environment, by means of the correct administration of natural resources, adequate processing of residues, as well as the recycling and re-usage of materials.



¿POR QUÉ INFRICO MEDCARE? / WHY INFRICO MEDCARE?



Seguridad y confianza

Security and confidence



Infrico es uno de los principales fabricantes de frío en España. Ofrece productos de alta calidad certificados por organismos externos. Es un referente en refrigeración a nivel mundial y ha desarrollado unos procedimientos de calidad específicos para la división Medicare, teniendo en cuenta la sensibilidad e importancia de los productos que se conservan en los equipos utilizados en este sector.

Infrico is one of the leading cooling product manufacturers in Spain. Our company offers high quality products certified by external agencies. It is a worldwide refrigeration benchmark and has developed specific procedures for the Medicare division, taking into account the sensitivity and importance of the products that are conserved in the equipment used in this sector.

Infrico Medicare garantiza la seguridad 24 horas al día / 365 días al año.

Infrico Medicare guarantees security 24 hours a day / 365 days a year.



Fiabilidad y protección

Reliability and protection



El sector sanitario, farmacéutico y de laboratorios exige unos requisitos muy estrictos de estabilidad de temperatura y fiabilidad. Por este motivo nuestros equipos incorporan un sistema de alarmas ópticas y acústicas, que avisan cuando la temperatura se encuentra fuera de los parámetros marcados, así como cuando se produce un corte de luz o una apertura de puerta demasiado larga. Además, es posible incorporar nuestro termostato anticongelación que provee de una doble protección. Igualmente, en el caso de fallo de corriente se conecta automáticamente una batería que alimenta el controlador y así permite seguir registrando la temperatura y las alarmas.

The healthcare, pharmaceutical and laboratory sector demands very strict temperature stability requirements and reliability. For this reason, our equipment incorporates a system of optical and acoustic alarms, which warn the users when the temperature passes the marked parameters, as well as when a power failure occurs or when the door has been open for too long. Furthermore, there is the option to incorporate our antifreeze thermostat that provides double protection. Likewise, in the case of a power failure, a battery is automatically connected to the controller which continues to record the temperature and alarms.





Listo para usar

Ready to use



Los equipos de refrigeración de Infrico Medcare se entregan totalmente programados con el rango de temperaturas y alarmas, por lo que el cliente solo tiene que enchufarlos para empezar a usarlos.

Infrico Medcare refrigeration equipment is delivered fully programmed with a range of temperatures and alarms, so the customer only has to plug them in and start using them.



Mantenimiento y limpieza sencilla

Simple maintenance and cleaning



Nuestros equipos disponen de amplios radios en los compartimentos interiores para facilitar la limpieza. Las puertas se mantienen abiertas a un ángulo de apertura de 105° lo que facilita el acceso al equipo. No obstante para asegurar la estabilidad térmica disponen de un mecanismo de cierre automático a partir de un ángulo de apertura de 80°. Todos los componentes interiores son desmontables y fáciles de limpiar. Igualmente todos los componentes de refrigeración y de control electrónico digital, se han incorporado en una posición segura y de muy fácil acceso.

Our equipment has rounded corners for easy cleaning in the interior compartments. The doors are kept open at an opening angle of 105° which facilitates access to the equipment. However, to ensure thermal stability, they also have a self-closing mechanism when the door opening angle is less than 80°. All interior components are detachable and easy to clean. In the same way, all the components of refrigeration and electronic digital control, have been incorporated in a safe position and they are easily accessible.



Cuidamos del medioambiente...
We care about the environment...



EFICIENCIA ENERGÉTICA / ENERGY EFFICIENCY



Eficiencia energética

Energy efficiency



El diseño del equipo y los componentes utilizados están elegidos para ofrecer al usuario un equipo de refrigeración eficiente y respetuoso con el medioambiente (iluminación LED, tecnología INVERTER, compresores de nueva generación, puertas con doble y triple acristalamiento con carga de argón etc.) Nuestros refrigeradores y congeladores aseguran la potencia frigorífica necesaria incluso en condiciones climáticas extremas.

The design of our equipment and components we use are chosen to offer our customers efficient and environmentally friendly refrigeration products [LED lighting, INVERTER technology, new generation compressors, doors with double and triple glazing with argon loading etc.] Our refrigerators and freezers ensure constant cooling power even in extreme climate conditions.

- Respeto y cuidado del medioambiente siguiendo la ISO 14001.
- Uso de refrigerantes naturales libres de CFC y HCFC respetuosos con el medio ambiente.
- Amplia gama de productos con tecnología INVERTER con alta eficiencia energética y bajo consumo.
- Cumpliendo con los requerimientos de reciclaje, gestión y reducción de residuos, con soluciones de embalaje sostenible.
- Compresores de nueva generación — alta eficiencia energética y bajo nivel sonoro.
- Iluminación LED, reduciendo el consumo energético hasta 90%, en comparación con fluorescentes tradicionales.
- Puertas de doble y triple acristalamiento templado con carga de argón.
- Aislamiento de poliuretano inyectado a alta presión libre de CFC's y HCFC's con densidad 40 Kg/m³.
- Condensadores y Evaporadores de gran superficie, para mejorar eficiencia energética y funcionamiento.
- Evaporadores con tratamiento anticorrosión para evitar fugas.
- Burletes magnéticos de triple cámara para evitar pérdidas de frío.
- Sistema de desescarche automático.
- Desescarche por gas caliente en toda la gama de equipos de baja temperatura.
- Continuas iniciativas de reducción de CO₂ para luchar contra el Calentamiento Global.

- Respecting and preserving the environment in agreement with ISO 14001.
- Use of CFC's and HCFC's free environmentally friendly natural refrigerants minimizing greenhouse gases.
- A wide range of products with INVERTER technology with high energy efficiency and low energy consumption.
- Compliant with recycling requirements, waste management and reduction with sustainable packaging solutions.
- New generation compressors — high energy efficiency and low noise level.
- LED Lighting, reducing energy consumption by 90% compared to traditional fluorescent lights.
- Double and triple tempered glass door with argon gas.
- CFC's and HCFC's free polyurethane insulation, high pressure injected with a density of 40 Kg/m³.
- Oversized Condensers and Evaporators to improve energy efficiency and performance.
- Coated Evaporators with anticorrosion material to prevent leaks.
- Triple magnetic chamber gasket to retain cold temperatures.
- Automatic defrost system.
- Hot gas defrost in all low temperature equipment.
- Continuous CO₂ reduction initiatives to fight Global Warming.



Todos los productos de Infrico Medicare disponen del sello de Origen Español, lo que significa que están fabricados en España y por una empresa española.

All Infrico Medicare products have Spanish Origin mark, which means that they are manufactured in Spain and by a Spanish company.



CERTIFICADOS DE CALIDAD / QUALITY CERTIFICATIONS



Infrico Medcare siguiendo su compromiso de calidad, está acreditada por un sistema de gestión basado en la norma **ISO 9001:2008** que engloba todos los equipos de nuestro catálogo e **ISO 13485:2016** de productos sanitarios.

Debido a la importancia del cuidado del medio ambiente tenemos también implementado un sistema de gestión ambiental basado en la norma internacional **ISO 14001:2004**, a través del cual se controla el cumplimiento de todos los requisitos legales y se ponen en práctica políticas de reducción de recursos naturales, reciclaje y gestión de residuos.

Infrico Medcare realiza su trabajo con las máximas garantías y seguridad; para ello ha implementado un sistema de prevención de riesgos laborales basado en el reglamento **OSHAS 18001:2007** manteniendo un sistema integrado de gestión: calidad-medio ambiente-prevención.

Infrico Medcare, follows its commitment to quality, which is accredited by a management system based on the **ISO 9001:2008** and **ISO 13485:2016** for medical devices that encompasses all the equipment in our catalogue.

Due to the importance of environmental care, we have also implemented an environmental management system based on the international standard **ISO 14001:2004**, which complies with all legal requirements and applies natural resource reduction policies, recycling and waste management.

Infrico Medcare does its work with the maximum guarantees and security. Therefore, it has implemented a system of occupational risk prevention based on the **OSHAS 18001:2007** regulation maintaining an integrated management system: quality-environment-prevention.



Los aparatos descritos en nuestro catálogo están conformes con las Directivas del Consejo DC2014/35/UE [Seguridad eléctrica] y DC2014/30/UE [Compatibilidad electromagnética].

Además han superado los ensayos de **equipos electromédicos** según las normas **EN 60601-1** y **EN 60601-1-2**.

Todos nuestros refrigeradores para banco de sangre son productos sanitarios **Clase IIa**, certificados por el **ON 0318** y fabricados conforme a la directiva **93/42/CEE**.

The equipment described in our catalogue complies with Council Directives DC2014/35/EU [Electrical Safety] and DC2014/30/UE [Electromagnetic Compatibility].

In addition, they have passed the tests of **electromedical equipment** according to standards **EN 60601-1** and **EN 60601-1-2**.

Our blood bank refrigerators are medical devices **Class IIa** certified by **ON 0318** and manufactured in accordance with directive **93/42/EEC**.



ESTABILIDAD DE TEMPERATURA / TEMPERATURE STABILITY

LA VENTILACIÓN INTERIOR FORZADA ASEGURA UNAS MÍNIMAS VARIACIONES DE TEMPERATURA Y UNA HUMEDAD ADECUADA PARA LA CONSERVACIÓN DE LOS MEDICAMENTOS Y SUS ENVASES.

RANGO DE ESTABILIDAD DEL PRODUCTO DE APROXIMADAMENTE $\pm 1^{\circ}\text{C}$ Y DE UNIFORMIDAD DE TEMPERATURA EN PRODUCTO MENOR DE $\pm 2^{\circ}\text{C}$.

INTERIOR FORCED VENTILATION ENSURES MINIMUM TEMPERATURE VARIATIONS AND ADEQUATE HUMIDITY FOR THE PRESERVATION OF MEDICINES AND THEIR PACKAGING.

PRODUCT STABILITY RANGE OF APPROXIMATELY $\pm 1^{\circ}\text{C}$ AND PRODUCT UNIFORMITY TEMPERATURE LESS THAN $\pm 2^{\circ}\text{C}$.



EVAPORACIÓN CON AIRE FORZADO

- Enfriamiento uniforme de la cámara.
- Rápida recuperación después de la apertura de la puerta.
- Mejor control de la humedad interior.

FORCED-AIR EVAPORATOR

- Uniform cooling.
- Quick recovery after door opening.
- Better internal humidity control.

Disponemos de un laboratorio propio con cámara climática, dedicado a los ensayos de nuestros equipos.

We have our own laboratory with a climatic chamber, dedicated exclusively to test our equipment.



INFRICO MEDCARE ENSAYA SUS EQUIPOS EN DIFERENTES CONDICIONES CLIMÁTICAS Y REALIZA UN MAPEO DE TEMPERATURAS EN EL AIRE Y DE PRODUCTO EN EL INTERIOR DE LA CÁMARA. TODO ELLO, PARA GARANTIZAR LA HOMOGENEIDAD DE LA TEMPERATURA DENTRO DE LOS RANGOS ESTABLECIDOS.

Para ello son usadas numerosas sondas de temperatura distribuidas según la norma UNE 60068.

- Sonda en cada estante—control de la temperatura del aire en los distintos niveles del equipo
- Sonda inmersa en líquido—control de la temperatura del producto
- Sonda en la salida del aire—control de la temperatura de salida del aire, en los distintos niveles
- Sonda en el retorno del aire—control de la temperatura del aire en la entrada del evaporador

INFRICO MEDCARE TESTS ITS EQUIPMENT IN DIFFERENT CLIMATE CONDITIONS AND PERFORMS A MAPPING OF TEMPERATURES IN THE AIR AND OF THE PRODUCT THROUGHOUT THE INTERIOR OF THE CHAMBER. ALL THIS, IS TO GUARANTEE THE HOMOGENEITY OF THE TEMPERATURE WITHIN THE ESTABLISHED RANGES.

The devices used to make the tests are 9 probes situated according UNE 60068.

- Probe in each shelf—control of the air temperature in the different levels of the equipment
- Probe immersed in liquid—control of the product temperature
- Probe at the air outlet—control of the temperature of the air outlet, at different levels
- Probe in exchanging air—control of the air temperature in the entrance to the evaporator

RENDIMIENTO ACREDITADO CERTIFIED PERFORMANCE

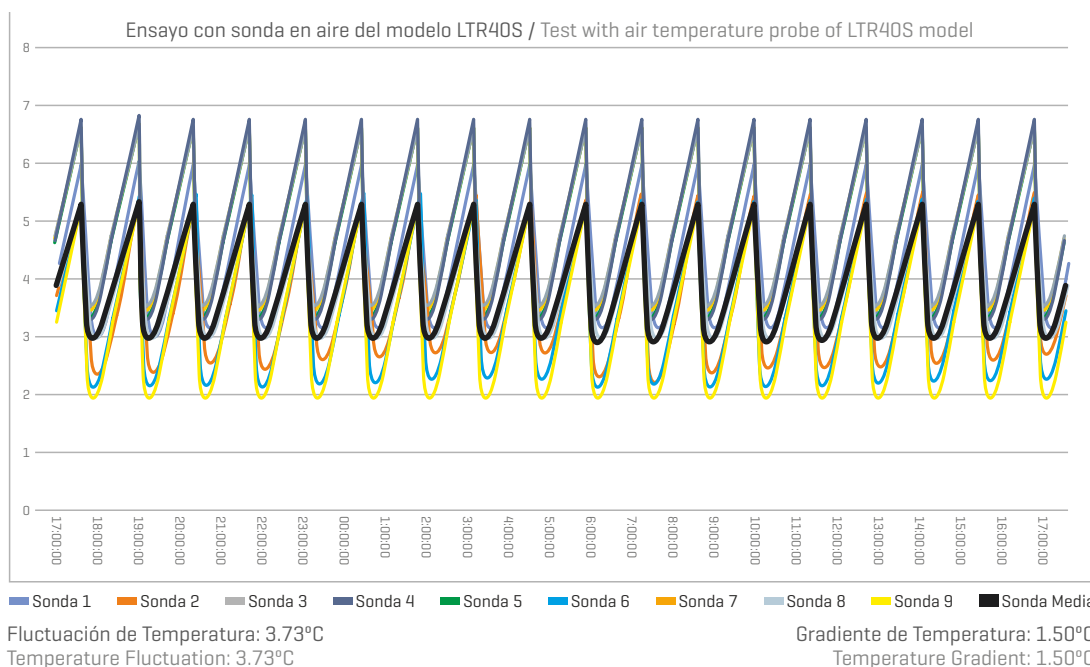
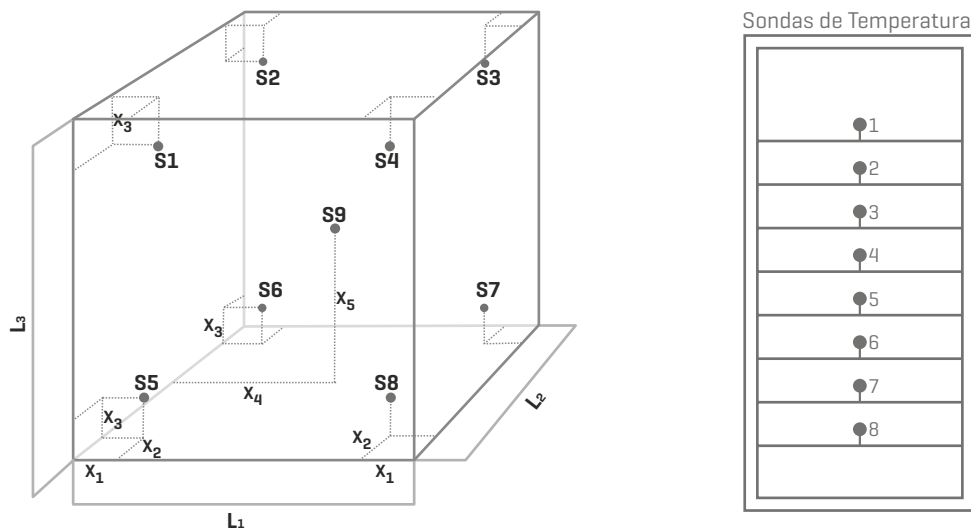

CONTROLADORES DE TEMPERATURA / TEMPERATURE CONTROLLERS

CONTROLADOR DIGITAL / DIGITAL CONTROLLER

FÁCIL E INTUITIVO — pantalla táctil

CONTROL PRECISO — sondas NTC

ESTABILIDAD Y UNIFORMIDAD — rango de estabilidad de producto de aproximadamente $\pm 1^{\circ}\text{C}$ y uniformidad de temperatura en producto menor de $\pm 2^{\circ}\text{C}$

DISPLAY DE GRAN TAMAÑO — buena visibilidad y precisión de $0,1^{\circ}\text{C}$

3 TIPOS DE ALARMAS ÓPTICAS Y ACÚSTICAS — bajada o subida de temperatura, fallo de sonda y puerta abierta

SEÑAL DE ALARMA REMOTA — contacto libre de potencial

MÚLTIPLES FUNCIONES OPCIONALES — USB, Datalogger Bluetooth o Wifi, Batería, etc.

EASY AND INTUITIVE - touch screen

PRECISE CONTROL - NTC probes

STABILITY AND UNIFORMITY - product stability range of approximately $\pm 1^{\circ}\text{C}$ and product uniformity temperature less than $\pm 2^{\circ}\text{C}$

GREAT SIZE DISPLAY - good visibility and 0.1°C accuracy

3 TYPES OF OPTICAL AND ACOUSTIC ALARMS - temperature rise or fall, probe failure and open door

REMOTE ALARM SIGNAL - Potential free contact

MULTIPLE OPTIONAL FUNCTIONS - USB, Datalogger Bluetooth or Wifi, Battery, etc.



CONTROLADOR DIGITAL PLUS / DIGITAL PLUS CONTROLLER

USB

Fácil descarga de los registros de datos y alarmas.

USB

Easy download of data logs and alarms.

CONECTIVIDAD

Posibilidad de monitorizar el funcionamiento vía Bluetooth o WIFI.

CONNECTIVITY

Possibility of monitoring via Bluetooth or WIFI.

PANTALLA TÁCTIL

Fácil e intuitivo. Estándar 5".

Opcional 7" en algunos modelos.

TOUCH SCREEN

Easy and intuitive. Standard 5".

Optional 7" in some models.



BATERÍA

Permite mantener el registro de temperatura y alarmas en el caso de fallo de alimentación.

BATTERY

Allows the maintenance of temperature and alarms register in case of a power failure.

POSIBILIDAD DE SELECCIÓN DE DIFERENTES IDIOMAS

Español, inglés, italiano, francés y alemán.

DIFFERENT LANGUAGES SELECTION OPTION

Spanish, English, Italian, French and German.

RS485 PUERTO DE COMUNICACIÓN MODBUS

Permite conectar el sistema con PC o red.

RS485 COMMUNICATION PORT MODBUS

Connects the system with PC or network.

SEÑAL DE ALARMA REMOTA

Contacto libre de potencial, permite la transferencia de las señales de aviso a un sistema externo.

REMOTE ALARM SIGNAL

Potential free contact, allows the transfer of warning signals to an external system.



DISPLAY:
Precisión de 0,1°C.

CONTROL PRECISO:
Sondas PT1000

ESTABILIDAD Y UNIFORMIDAD:
Rango de estabilidad de producto de aproximadamente $\pm 1^{\circ}\text{C}$ y de uniformidad de temperatura en producto menor de $\pm 2^{\circ}\text{C}$.

DISPLAY:
Accuracy of 0.1°C.

PRECISE CONTROL:
PT1000 probes

STABILITY AND UNIFORMITY:
Product stability range of approximately $\pm 1^{\circ}\text{C}$ and product uniformity temperature less than $\pm 2^{\circ}$.

MÚLTITUD DE ALARMAS ÓPTICAS Y ACÚSTICAS
Bajada o subida de temperatura, fallo de alimentación, fallo de sonda, batería descargada, puerta abierta, mantenimiento de compresor, condensador sucio...

DATALOGGER
Registro de temperaturas e histórico de alarmas

INFORMACIÓN DETALLADA DEL EQUIPO
Interfaz gráfica de 5 pulgadas indicando temperaturas máximas y mínimas

ASISTENTE DE CONFIGURACIÓN
Página de bienvenida para una rápida y fácil configuración mediante la elección de los principales parámetros del controlador

CONTRASEÑA NUMÉRICA
Sistema de control protegido con contraseña numérica

USUARIOS CONFIGURABLES
Gestión de permisos a diferentes usuarios

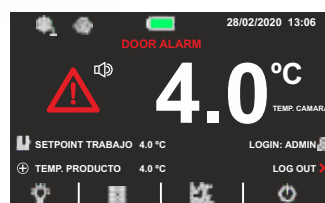

VARIETY OF OPTICAL AND ACOUSTIC ALARMS
Temperature rise or fall, power failure, low battery, open door, compressor maintenance, dirty condenser...

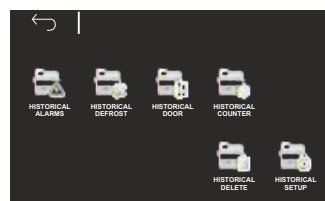

DATALOGGER
Temperature log and alarm history

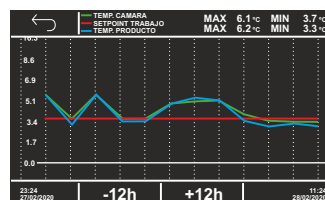

DETAILED EQUIPMENT INFORMATION
5 inches Graphic interface indicating maximum and minimum temperatures

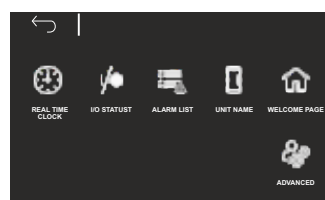

CONFIGURATION ASSISTANT
Welcome page for quick and easy configuration by choosing the main controller parameters

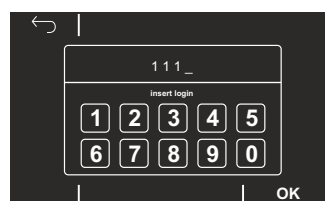

LOCK CODE
Lock code to access the control system

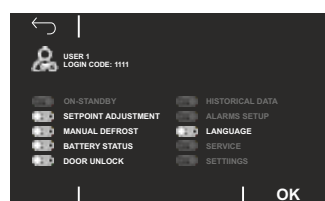

CONFIGURABLE USERS
Permission management to different users





PHARMA CARE

El sector de farmacias, hospitales y consultas médicas es especialmente exigente en cuanto a estabilidad de temperatura. Infrico Medcare en sus líneas de productos Pharma CARE y Pharma CARE PLUS ha incorporado una serie de características específicas que garantizan la seguridad en la conservación de medicamentos y vacunas 24 horas al día y 365 días al año. Esto es fundamental para nuestros clientes.

Todos nuestros refrigeradores de la línea Pharma CARE y Pharma CARE PLUS, están diseñados según la normativa DIN 58345.

The sector of pharmacies, hospitals and medical practices is especially demanding in terms of temperature stability. Infrico Medcare in its Pharma CARE and Pharma CARE PLUS product lines has incorporated a series of specific characteristics that guarantee the safety in the conservation of medicines and vaccines 24 hours a day and 365 days a year. This is crucial for our customers.

All our refrigerators of the Pharma CARE PLUS and Pharma CARE PLUS lines are designed in compliance with DIN 58345.

DIN 58345



Según la DIN 58345 los aparatos deben de tener las siguientes características:

- Temperatura de operación entre +2°C y +8°C.
- Temperatura ambiente del lugar de instalación admitida entre +10°C y +35°C.
- Fácil limpieza y desinfección de la cámara; resistente al agua y con protección contra corrosión.
- Capacidad de carga mecánica de las piezas montadas uniforme de 100 kg/m².
- Puertas dotadas de cerraduras.
- Emisión acústica por debajo de 60 dB [A]
- Alarma en caso de fallo de corriente durante un mínimo de 12 h.
- Alarma óptica-acústica en caso de desviación de la temperatura.
- Contacto de alarma libre de potencial.
- Elemento de seguridad para prevenir de que la temperatura baje de +2°C.

According to DIN 58345 the devices must comply with the following requirements:

- Operating temperature range from +2°C to +8°C.
- Interior room temperature of the installation site is accepted between +10°C and +35°C.
- Interior is easy to clean and disinfect; water resistant and with corrosion protection.
- Mechanical capacity load of uniformly mounted parts of 100 kg/m².
- Doors fitted with locks.
- Acoustic emission below 60 dB [A]
- Power failure alarm for a minimum of 12 h.
- Optical-acoustic alarm in case of temperature deviation.
- Potential free alarm contact.
- Safety device to prevent the temperature going below +2°C

PHARMA

1

HEALTH

2

LAB

3

4

5

6

7

8



TECNOLOGÍA INVERTER / INVERTER TECHNOLOGY

Haciendo uso de la tecnología INVERTER en nuestros equipos, conseguimos una mayor estabilidad de temperatura, junto con un menor nivel sonoro y por supuesto, una destacada eficiencia energética.

Using INVERTER technology in our equipment, we achieve greater temperature stability, lower noise level and outstanding energy efficiency.



MENOR CONSUMO ENERGÉTICO
LOWER ENERGY CONSUMPTION



MAYOR ESTABILIDAD DE TEMPERATURA
GREATER TEMPERATURE STABILITY



MENOR NIVEL SONORO
LOWER NOISE LEVEL

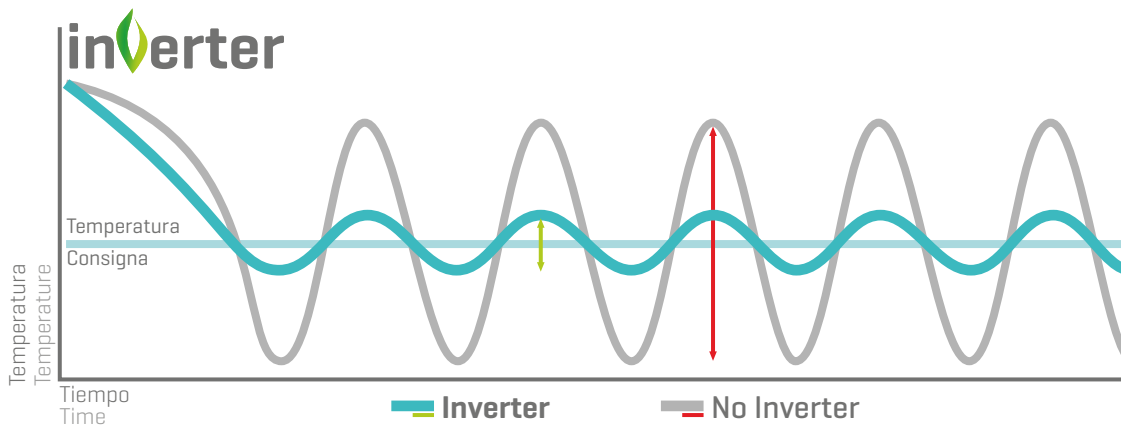

En los equipos convencionales no INVERTER, el compresor funciona a velocidad máxima hasta alcanzar la temperatura de consigna, y una vez es alcanzada, se detiene, repitiéndose sucesivamente con continuos arranques y paradas, provocando un mayor consumo y una menor estabilidad de temperatura.

Conventional non-INVERTER equipment, the compressor operates at maximum speed until reaching the setpoint temperature, and once it is reached, it stops, repeating successively with continuous starts and stops, causing greater energy consumption and lower temperature stability.

En cambio, con tecnología INVERTER, el compresor una vez entra en funcionamiento, varía su velocidad para adaptarse al diferencial de temperatura que existe en cada momento, evitando los arranques y paradas del compresor que aumentan el consumo y hacen oscilar en mayor medida la temperatura del equipo.

In equipment with INVERTER technology, once the compressor starts operating, it adjusts the operational speed to the setpoint temperature, avoiding the starts and stops of the compressor that increase energy consumption and make greater the oscillation of the equipment temperature.

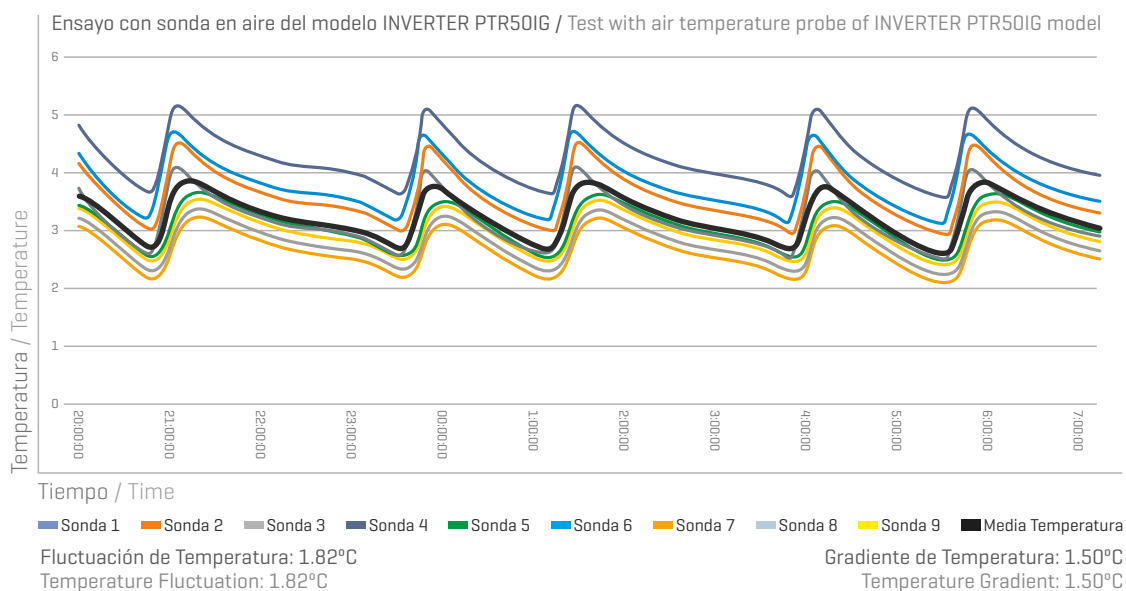



NUESTRA AMPLIA EXPERIENCIA EN FABRICACIÓN DE EQUIPOS DE FRÍO A NIVEL MUNDIAL Y CUMPLIENDO CON LAS ESPECIFICACIONES O REQUERIMIENTOS DE CALIDAD DE DIFERENTES MERCADOS, HACE QUE PUEDES CONFIAR EN INFRICO MEDCARE.

OUR EXTENSIVE EXPERIENCE AS A WORLDWIDE MANUFACTURER OF COOLING EQUIPMENT AND THE SPECIFICATIONS OR QUALITY REQUIREMENTS OF DIFFERENT MARKETS THAT WE COMPLY WITH, ENSURES YOU CAN RELY ON INFRICO MEDCARE.

PHARMA CARE

PHARMA CARE SERIES



La GAMA Pharma CARE está compuesta de diferentes modelos para adaptarnos a cualquier espacio o necesidad. Así, disponemos de modelos sobre encimera, bajo encimera y verticales, con volúmenes desde los 70 a los 360 litros.

Pharma CARE SERIES offers pharmaceutical refrigerators in different sizes and storage capacities, in order to fit all possible space requirements and needs. Models range from countertop, underbench or upright versions which are available with model variety from 70 to 360 litres.

Está diseñada de acuerdo a la normativa **DIN 58345**.

These models are designed according to **DIN 58435** standard.



PER07S / 70 L PER15S / 150 L PER36S / 360 L PER07G / 70 L PER15G / 150 L PER36G / 360 L

Pág. 26

GAMA PHARMA CARE PLUS

PHARMA CARE PLUS SERIES



Esta gama de armarios refrigerados para farmacias pretende satisfacer las necesidades de los clientes más exigentes. Para ello, dichos modelos hacen uso de la tecnología **INVERTER**, consiguiendo una mayor eficiencia energética y un bajo consumo y menor nivel sonoro.

This series offers high performance refrigerators for the storage of pharmaceutical preparations to meet the most demanding applications. In order to achieve that purpose, these models have incorporated **INVERTER** technology with high energy efficiency and low energy consumption and lower noise level.

Está diseñada de acuerdo a la normativa **DIN 58345**. Dispone de modelos desde 170 a 1300 litros, todos ellos con controlador Digital Plus.

These models are designed according to **DIN 58435** standard. Capacity ranges from 170 to 1300 litres, and all models with Digital Plus. controller.

Todos estos modelos están disponibles con puerta ciega o de cristal.

Solid or glass doors are available in the whole range.

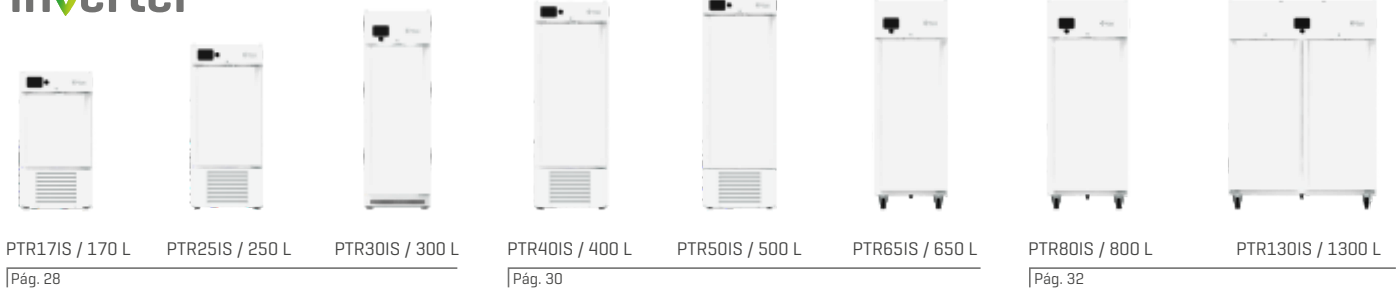

PTR17IS / 170 L PTR25IS / 250 L PTR30IS / 300 L PTR40IS / 400 L PTR50IS / 500 L PTR65IS / 650 L PTR80IS / 800 L PTR130IS / 1300 L

Pág. 28

Pág. 30

Pág. 32



PTR17IG / 170 L PTR25IG / 250 L PTR30IG / 300 L PTR40IG / 400 L PTR50IG / 500 L PTR65IG / 650 L PTR80IG / 800 L PTR130IG / 1300 L

Pág. 28

Pág. 30

Pág. 32



CARACTERÍSTICAS GENERALES / GENERAL FEATURES



CONTROLADOR DIGITAL (modelos gama Pharma CARE] o **CONTROLADOR DIGITAL PLUS** (modelos gama Pharma CARE PLUS)
¡Elige según tus necesidades!

DIGITAL CONTROLLER (Pharma CARE range models] or **DIGITAL PLUS CONTROLLER** (Pharma CARE and Pharma CARE PLUS range models)
Choose according to your needs!



CERRADURA / SENSOR DE PUERTA
Todos nuestros equipos disponen de cerraduras y sensores de puerta abierta, para garantizar la seguridad de los productos almacenados, controlando el tiempo de apertura y el funcionamiento de los ventiladores.

LOCK / DOOR SENSOR
All our equipment has locks and open door sensors, to guarantee the security of the stored products by controlling opening time and fans functioning.



ILUMINACIÓN LED
El uso de iluminación LED reduce el consumo energético del equipo y mejora la homogeneidad de la temperatura en el interior.

LED LIGHTING
The use of LED lighting reduces the energy consumption and improves the homogeneity of the temperature inside the cabinet.

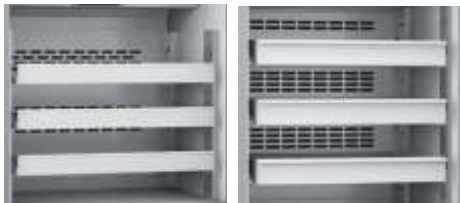

ALMACENAMIENTO FLEXIBLE
Nuestro nuevo sistema de estantes/cajones permite ajustar la posición de los mismos, variar su número, cambiar estantes por cajones y viceversa. Esto proporciona el ajuste del equipo a sus necesidades y comodidad de almacenamiento de medicamentos o vacunas de diferentes tamaños.

FLEXIBLE STORAGE SOLUTIONS
Our new shelf / drawer system allows you to adjust their position, vary their number, change shelves for drawers and vice versa or compliment them with dividers. This provides the fit of the equipment to your needs and storage convenience of medications or vaccines of different sizes.



ESTILO DE PUERTAS
En todos nuestros equipos existe la posibilidad de elegir entre puerta ciega o de cristal. Todas nuestras puertas son abatibles y reversibles.

DOOR STYLE
It is possible to choose solid or glass doors in our whole range. All our doors are hinged and reversible.



BURLETE DE ARPÓN PARA UN CAMBIO RÁPIDO Y FÁCIL
Es ideal para mantener una higiene óptima y para facilitar los trabajos de mantenimiento.

EASY REMOVABLE DOOR GASKET
It is ideal to maintain optimal hygiene and facilitate maintenance work.



AMPLIOS RADIOS
Los interiores presentan amplios radios en las esquinas, que facilitan su limpieza.

ROUNDED CORNERS
The interiors have rounded corners, which facilitate their cleaning.



inverter

BATERÍA

Permite mantener el registro de temperatura y alarmas en el caso de fallo de alimentación.

BATTERY

Allows the maintenance of temperature and alarms register in case of a power failure.

INVERTER

Tecnología INVERTER [modelos gama Pharma CARE PLUS] con alta eficiencia energética y bajo consumo.

INVERTER

INVERTER technology [Pharma CARE PLUS range models] with high energy efficiency and low energy consumption.

TERMOSTATO DIGITAL ANTICONGELACIÓN

Este dispositivo imposibilita al producto a bajar su temperatura por debajo de +2°C.

FREEZING PROTECTION ELECTRONIC CONTROLLER

Safety thermostat prevents the temperature dropping below +2°C.

BANDEJA EVAPORATIVA

Nuestros equipos llevan incorporada una bandeja para evaporar de manera automática el agua del desescarche.

EVAPORATION PAN

Our equipment has a built-in tray to evaporate automatically defrosted water.

DESESCARCHES AUTOMÁTICOS INTELIGENTES

Nuestros equipos cuentan con desescarche automático, para asegurar una refrigeración uniforme en el tiempo y menos mantenimiento. Además, el equipo analiza su funcionamiento y realiza los desescarches solo cuando es necesario para mejorar la estabilidad de la temperatura.

ADVANCED DEFROST SYSTEM

Built-in to ensure uniform cooling over time and to facilitate maintenance. In addition, the equipment analyses its operation and only defrosts when it is necessary, to improve the stability of the temperature.

GASES REFRIGERANTES NATURALES HC

Libre de CFC y HCFC, biodegradable.

NATURAL HC COOLING GAS

CFC's and HCFC's free, biodegradable.



RUEDAS / PATAS REGULABLES / REGULADORES DE ALTURA

En todos nuestros armarios existe la posibilidad de ser equipados con ruedas para facilitar el desplazamiento y la limpieza.

CASTERS / ADJUSTABLE LEGS / HEIGHT REGULATORS

In our whole range, there is a possibility to incorporate casters to facilitate displacement and cleaning.

PHARMA

1

HEALTH

2

LAB

3

4

5

6

7

8





- PHARMA
- 1
- HEALTH
- 2
- LAB
- 3
- 4
- 5
- 6
- 7
- 8



ARMARIO DE REFRIGERACIÓN PHARMA CARE / PHARMA CARE REFRIGERATOR

DIN 58345



GAMA SERIES	Pharma CARE	Pharma CARE	Pharma CARE	Pharma CARE	Pharma CARE	Pharma CARE
MODELO MODEL	PER07S	PER07G	PER15S	PER15G	PER36S	PER36G
Rango T* Temperature range [°C]	+2 / +8	+2 / +8	+2 / +8	+2 / +8	+2 / +8	+2 / +8
Capacidad Nominal [litros] Nominal Capacity [litres]	70	70	150	150	360	360
Medidas Exterior [mm] L x P x A Exterior dimensions [mm] W x D x H	445 x 526 x 818	445 x 508 x 818	600 x 637 x 823	600 x 628 x 823	620 x 634 x 1858	620 x 625 x 1858
Medidas Interior [mm] L x P x A Interior dimensions [mm] W x D x H	358 x 312 x 523	358 x 323 x 523	505 x 457 x 452	505 x 460 x 452	541 x 450 x 1448	541 x 460 x 1448
Claro de puerta [mm] L x A Door opening [mm] W x H	358 x 516	358 x 516	505 x 555	505 x 552	534 x 1441	534 x 1441
Espesor Aislamiento [mm] Insulation thickness [mm]	40	40	45	45	40	40
Acabado Exterior Exterior finishing	Acero galvanizado plastificado blanco White plastic coated galvanised steel					
Acabado Interior Interior finishing	Acero galvanizado plastificado blanco White plastic coated galvanised steel					
Nº Estantes Shelves Number	2	2	3	3	6	6
Dimensiones Estante [mm] L x P Shelf/Drawer Size [mm] W x D	315 x 248	315 x 248	458 x 398	458 x 398	488 x 398	488 x 398
Material Estantes Shelves Material	Acero galvanizado con pintura Epoxi Epoxy coated galvanised steel					
Intercambiabilidad de Estantes/Cajones Interchangeable Shelves/Drawers	No	No	Si Yes	Si Yes	Si Yes	Si Yes
Tipo de Puerta Door Type	Ciega Solid	Cristal Glass	Ciega Solid	Cristal Glass	Ciega Solid	Cristal Glass
Cerradura Lock	Si Yes					
Salida USB USB Port	No					
Datalogger Datalogger	Opcional Optional					
Batería Battery	Si Yes					
Sonda simulación producto Product temperature simulation probe	Opcional Optional					
Sonda de temperatura ambiente Interior room temperature probe	Opcional Optional					
Termostato anticongelación Freezing protection controller	Si Yes					
Tipo de Controlador Controller type	Digital					
Tipo de Refrigerante Refrigerant type	R600a	R600a	R290	R290	R290	R290
Potencia Eléctrica [W] Electric power [W]	113	113	191	191	210	210
Tensión/Frecuencia [V / Hz] Voltage/Frequency [V / Hz]	230 / 50					
Peso [kg] Weight [kg]	45	49	57	60	117	128

* Pruebas realizadas con una temperatura ambiente de +25°C
* Measured at +25°C ambient temperature and



PER07

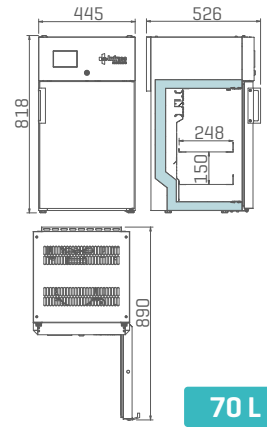

70 L



PER15

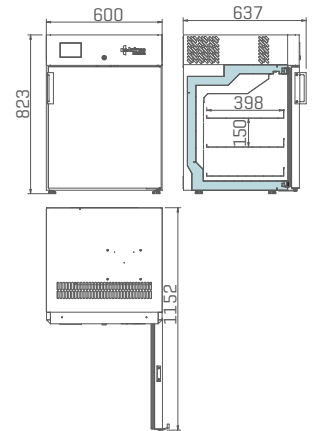

150 L



PER36

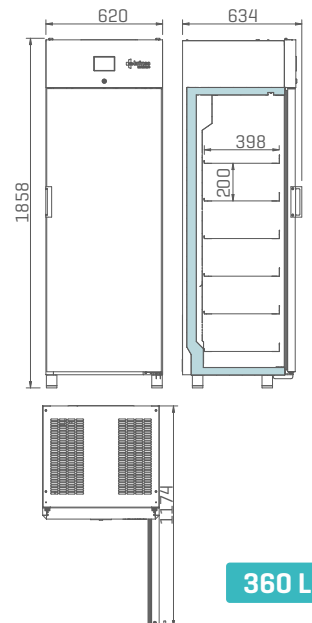

360 L

PHARMA

1

HEALTH

2

LAB

3

4

5

6

7

8



ARMARIO DE REFRIGERACIÓN PHARMA CARE PLUS / PHARMA CARE PLUS REFRIGERATOR

DIN 58345

inverter



* Pruebas realizadas con una temperatura ambiente de +25°C
* Measured at +25°C ambient temperature and

GAMA SERIES	Pharma CARE PLUS	Pharma CARE PLUS	Pharma CARE PLUS	Pharma CARE PLUS	Pharma CARE PLUS	Pharma CARE PLUS
MODELO MODEL	PTR17IS	PTR17IG	PTR25IS	PTR25IG	PTR30IS	PTR30IG
Rango T* Temperature range (°C)	+2 / +8	+2 / +8	+2 / +8	+2 / +8	+2 / +8	+2 / +8
Capacidad Nominal [litros] Nominal Capacity [litres]	170	170	250	250	300	300
Medidas Exterior [mm] L x P x A Exterior dimensions [mm] W x D x H	670 x 683 x 1293	670 x 683 x 1293	670 x 683 x 1538	670 x 683 x 1538	595 x 621 x 1876	595 x 621 x 1876
Medidas Interior [mm] L x P x A Interior dimensions [mm] W x D x H	568 x 484 x 668	568 x 503 x 668	568 x 484 x 913	568 x 503 x 913	483 x 426 x 1521	483 x 446 x 1521
Claro de puerta [mm] L x A Door opening [mm] W x H	568 x 610	568 x 610	568 x 855	568 x 855	483 x 1311	483 x 1311
Espesor Aislamiento [mm] Insulation thickness [mm]	50	50	50	50	55	55
Acabado Exterior Exterior finishing	Acero galvanizado plastificado blanco White plastic coated galvanised steel					
Acabado Interior Interior finishing	Acero galvanizado plastificado blanco White plastic coated galvanised steel					
Nº Cajones Drawers Number	3	3	4	4	7	7
Dimensiones Cajón [mm] L x P Drawer Size [mm] W x D	500 x 443	500 x 443	500 x 443	500 x 443	418 x 398	418 x 398
Material Cajones Drawers Material	Acero galvanizado con pintura Epoxi Epoxy coated galvanised steel					
Intercambiabilidad de Estantes/Cajones Interchangeable Shelves/Drawers	Si Yes					
Tipo de Puerta Door Type	Ciega Solid	Cristal Glass	Ciega Solid	Cristal Glass	Ciega Solid	Cristal Glass
Cerradura Lock	Si Yes					
Salida USB USB Port	Si Yes					
Datalogger Datalogger	Si Yes					
Batería Battery	Si Yes					
Sonda simulación producto Product temperature simulation probe	Opcional Optional					
Sonda de temperatura ambiente Interior room temperature probe	Si Yes					
Termostato anticongelación Freezing protection controller	Si Yes					
Tipo de Controlador Controller type	Digital Plus					
Tipo de Refrigerante Refrigerant type	R600a					
Potencia Eléctrica [W] Electric power [W]	133	138	136	144	332	352
Tensión/Frecuencia [V / Hz] Voltage/Frequency [V / Hz]	230 / 50					
Peso [kg] Weight [kg]	91	96	112	1125	121	136



PTR17I

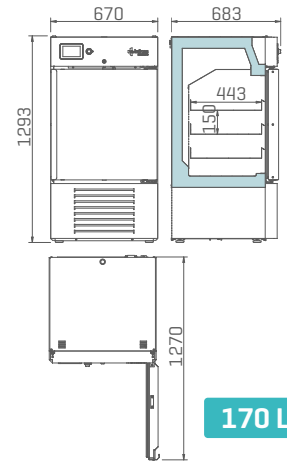

170 L



PTR25I

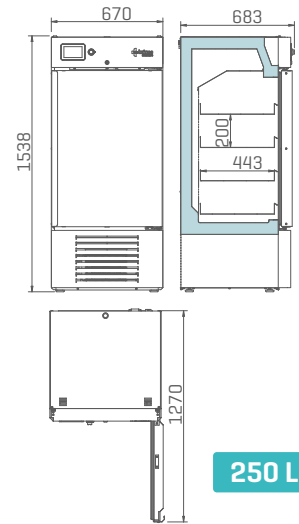

250 L



PTR30I

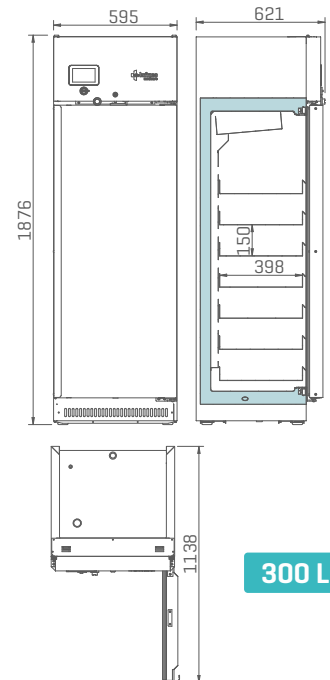

300 L

PHARMA

1

HEALTH

2

LAB

3

4

5

6

7

8



ARMARIO DE REFRIGERACIÓN PHARMA CARE PLUS / PHARMA CARE PLUS REFRIGERATOR

DIN 58345



inverter

* Pruebas realizadas con una temperatura ambiente de +25°C
* Measured at +25°C ambient temperature and

GAMA SERIES	Pharma CARE PLUS	Pharma CARE PLUS	Pharma CARE PLUS	Pharma CARE PLUS	Pharma CARE PLUS	Pharma CARE PLUS
MODELO MODEL	PTR40IS	PTR40IG	PTR50IS	PTR50IG	PTR65IS	PTR65IG
Rango T° Temperature range (°C)	+2 / +8	+2 / +8	+2 / +8	+2 / +8	+2 / +8	+2 / +8
Capacidad Nominal [litros] Nominal Capacity [litres]	400	400	500	500	650	650
Medidas Exterior [mm] L x P x A Exterior dimensions [mm] W x D x H	670 x 683 x 1963	670 x 683 x 1963	687 x 747 x 2018	687 x 747 x 2018	687 x 870 x 1955	687 x 870 x 1955
Medidas Interior [mm] L x P x A Interior dimensions [mm] W x D x H	568 x 484 x 1338	570 x 504 x 1338	577 x 525 x 1356	577 x 543 x 1356	534 x 633 x 1207	534 x 654 x 1207
Claro de puerta [mm] L x A Door opening [mm] W x H	568 x 1280	568 x 1280	577 x 1348	577 x 1348	534 x 1350	534 x 1350
Espesor Aislamiento [mm] Insulation thickness [mm]	50	50	55	55	75	75
Acabado Exterior Exterior finishing	Acero galvanizado plastificado blanco White plastic coated galvanised steel					
Acabado Interior Interior finishing	Acero galvanizado plastificado blanco White plastic coated galvanised steel			Acero Inoxidable Stainless steel		
Nº Cajones Drawers Number	7					
Dimensiones Cajón [mm] L x P Drawer Size [mm] W x D	500 x 443	500 x 443	510 x 473	510 x 473	452 x 585	452 x 585
Material Cajones Drawers Material	Acero galvanizado plastificado blanco White plastic coated galvanised steel			Acero Inoxidable Stainless steel		
Intercambiabilidad de Estantes/Cajones Interchangeable Shelves/Drawers	Si Yes					
Tipo de Puerta Door Type	Ciega Solid	Cristal Glass	Ciega Solid	Cristal Glass	Ciega Solid	Cristal Glass
Cerradura Lock	Si Yes					
Salida USB USB Port	Si Yes					
Datalogger Datalogger	Si Yes					
Batería Battery	Si Yes					
Sonda simulación producto Product temperature simulation probe	Opcional Optional					
Sonda de temperatura ambiente Interior room temperature probe	Si Yes					
Termostato anticongelación Freezing protection controller	Si Yes					
Tipo de Controlador Controller type	Digital Plus					
Tipo de Refrigerante Refrigerant type	R600a			R290		
Potencia Eléctrica [W] Electric power [W]	133	152	132	152	426	445
Tensión/Frecuencia [V / Hz] Voltage/Frequency [V / Hz]	230 / 50					
Peso [kg] Weight [kg]	139	153	150	158	153	160

Nos reservamos el derecho a modificar las especificaciones técnicas y constructivas sin previo aviso.

We reserve the right to modify technical and construction specifications without prior notice.



PTR40I

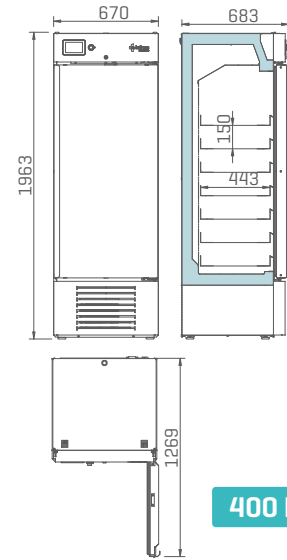

PTR50I

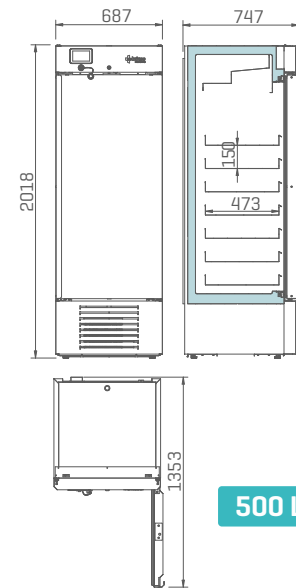

PTR65I

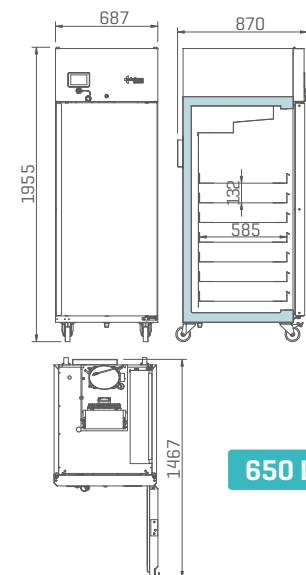

PHARMA

1

HEALTH

2

LAB

3

4

5

6

7

8



ARMARIO DE REFRIGERACIÓN PHARMA CARE PLUS / PHARMA CARE PLUS REFRIGERATOR

DIN 58345



inverter

* Pruebas realizadas con una temperatura ambiente de +25°C

GAMA SERIES	Pharma CARE PLUS	Pharma CARE PLUS	Pharma CARE PLUS	Pharma CARE PLUS
MODELO MODEL	PTR80IS	PTR80IG	PTR130IS	PTR130IG
Rango T° Temperature range [°C]	+2 / +8	+2 / +8	+2 / +8	+2 / +8
Capacidad Nominal [litros] Nominal Capacity [litres]	800	800	1300	1300
Medidas Exterior [mm] L x P x A Exterior dimensions [mm] W x D x H	797 x 1000 x 1955	797 x 1000 x 1955	1385 x 834 x 1955	1385 x 834 x 1955
Medidas Interior [mm] L x P x A Interior dimensions [mm] W x D x H	645 x 803 x 1388	645 x 823 x 1388	1234 x 681 x 1388	1234 x 702 x 1388
Claro de puerta [mm] L x A Door opening [mm] W x H	645 x 1350	645 x 1350	534 x 1350	534 x 1350
Espesor Aislamiento [mm] Insulation thickness [mm]	75			
Acabado Exterior Exterior finishing	Acero galvanizado plastificado blanco White plastic coated galvanised steel			
Acabado Interior Interior finishing	Acero Inoxidable Stainless steel			
N° Cajones Drawers Number	7	7	14	14
Dimensiones Cajón [mm] L x P Drawer Size [mm] W x D	564 x 750	564 x 750	452 x 585	452 x 585
Material Cajones Drawers Material	Acero Inoxidable Stainless steel			
Intercambiabilidad de Estantes/Cajones Interchangeable Shelves/Drawers	Si Yes			
Tipo de Puerta Door Type	Ciega Solid	Cristal Glass	Ciega Solid	Cristal Glass
Cerradura Lock	Si Yes			
Salida USB USB Port	Si Yes			
Datalogger Datalogger	Si Yes			
Batería Battery	Si Yes			
Sonda simulación producto Product temperature simulation probe	Opcional Optional			
Sonda de temperatura ambiente Interior room temperature probe	Si Yes			
Termostato anticongelación Freezing protection controller	Si Yes			
Tipo de Controlador Controller type	Digital Plus			
Tipo de Refrigerante Refrigerant type	R290			
Potencia Eléctrica (W) Electric power (W)	434	442	471	510
Tensión/Frecuencia [V / Hz] Voltage/Frequency [V / Hz]	230 / 50			
Peso [kg] Weight [kg]	172	178	208	225

Nos reservamos el derecho a modificar las especificaciones técnicas y constructivas sin previo aviso.

We reserve the right to modify technical and construction specifications without prior notice.



PTR80I

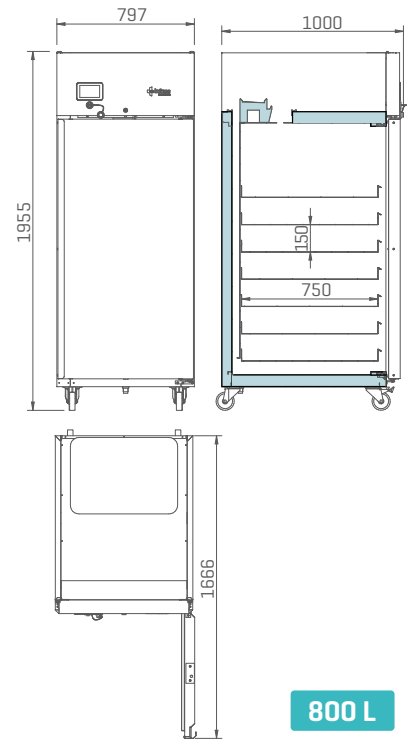

PTR130I

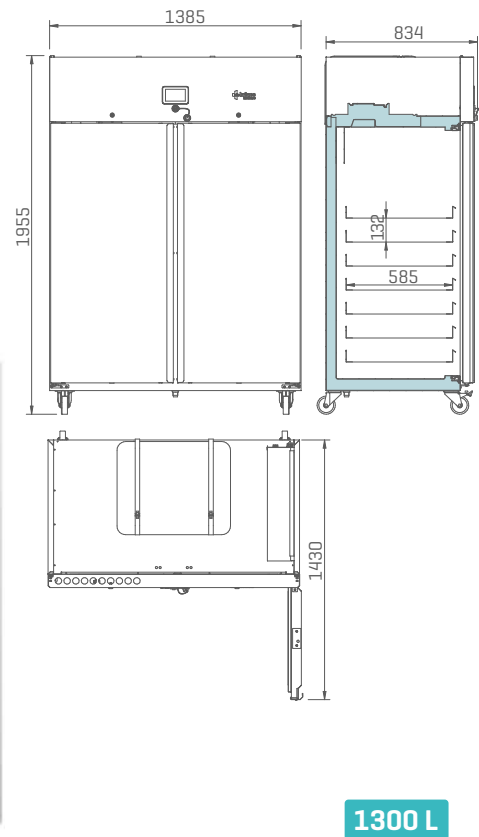

PHARMA

1

HEALTH

2

LAB

3

4

5

6

7

8





HEALTH CARE

El almacenamiento seguro de productos de gran valor como la sangre o el concentrado de hematíes es imprescindible en la medicina. Todos nuestros refrigeradores para banco de sangre son productos sanitarios **Clase IIa** certificados por el **ON 0318** y fabricados conforme a la directiva **93/42/CEE**.

Presentamos nuestra gama de equipos de refrigeración para bancos de sangre, teniendo como principales objetivos la confiabilidad, seguridad y la facilidad de uso. Mantienen una temperatura interna homogénea de +2°C a +6°C. Para ello, hemos diseñado nuestros equipos de acuerdo a la norma **DIN 58371** por lo que incorporan una serie de mejoras tendentes a asegurar la conservación de las bolsas de sangre.

Safe storage for high-value products such as blood or concentrated red blood cells is essential in medicine. All our blood bank refrigerators are medical device **Class IIa** certified by **ON 0318** and manufactured in compliance with directive **93/42/EEC**.

We present our range of refrigeration equipment for blood banks, with the main objective being the reliability, safety and easy use. They are designed to maintain a homogeneous internal temperature of +2°C to +6°C. For that purpose, we have incorporated a series of improvements aimed at ensuring the preservation of blood bags and in compliance with **DIN 58371**.

DIN 58371

La norma DIN 58371 marca los siguientes requisitos:

- Temperatura de operación entre +2°C y +6°C
- Temperatura ambiente del lugar de instalación admitida entre +10°C y +35°C
- Monitorización de la temperatura interior [+4°C]
- Fácil limpieza y desinfección de la cámara
- Capacidad de carga mecánica de las piezas montadas uniforme de 100kg/m²
- Puertas dotadas de cerraduras
- Alarma en caso de fallo de corriente durante un mínimo de 12 h
- Sistema de alarma óptica y acústica en caso de desviación de la temperatura por encima de +6°C y por debajo de +2°C
- Contacto libre de potencial para transmisión de alarma
- Dispositivo de seguridad para prevenir que las bolsas de sangre se enfríen por debajo de +2°C

DIN 58371 sets the following requirements:

- Operating temperature range from +2°C to +6°C
- Interior room temperature at the installation site is accepted between +10°C and +35°C
- The interior temperature is monitored [+4°C]
- Interior is easy to clean and disinfect; water resistant and with corrosion protection
- Drawers are able to withstand uniform loads of 100 kg/m²
- Doors fitted with locks
- Power failure alarm for a minimum of 12h
- Acoustic / visual alarm signal in case of temperature deviations, if temperature values are higher than +6°C or lower than +2°C
- Potential free contact for alarm transmission
- Safety device to prevent the temperature of blood bags going below +2°C





BANCOS DE SANGRE CERTIFICADOS / CERTIFIED BLOOD BANKS

El compromiso de Infrico Medcare con la seguridad es máximo, por ello nuestros equipos refrigeradores para bancos de sangre han sido acreditados por un sistema de gestión de la calidad basado en la norma **UNE-ENISO 13485:2016** de productos sanitarios.

Además, todos nuestros equipos han superado los ensayos de equipos electromédicos según las normas **EN 60601-1** y **EN 60601-1-2**.

En el caso de los refrigeradores para banco de sangre, son productos sanitarios **Clase IIa** certificados por el **ON 0318** y fabricados conforme a la directiva **93/42/CEE**.

The commitment of Infrico Medcare with safety of its products is the main objective. Therefore, all blood bank refrigerators have been accredited by a quality management system based on the **ISO 13485:2016** of medical devices.

In addition, all our equipment have passed the test of electromedical equipment according to standards **EN 60601-1** and **EN 60601-1-2**.

Our blood bank refrigerators are **Class IIa** medical devices certified by **ON 0318** and manufactured in compliance with directive **93/42/EEC**.



La certificación como **producto sanitario IIa** por el **ON 0318** [Organismo Notificado] se obtiene tras un exigente proceso de análisis de la documentación técnica del producto.

Dicho proceso comienza con una presentación del marcado CE, describiendo las características del producto, para luego una posterior confirmación de la categoría del producto sanitario por parte de la Autoridad competente, en el caso de España, la Agencia Española de Medicamentos y Productos Sanitarios [AEMPS].

Este Organismo Notificado revisa que el sistema de gestión de la calidad y/o producto es conforme a lo recogido en la documentación técnica a través de visitas al fabricante con cierta periodicidad.

The certification as a **Medical Device Class IIa** by **ON 0318** [Notified Body] is obtained after a demanding process of analysis of the technical documentation of the product.

This process begins with a presentation of the CE mark, describing the characteristics of the product, and then a subsequent confirmation of the category of the medical device by the Competent Authority, in the case of Spain, the Spanish Agency for Medicines and Health Products [AEMPS].

This Notified Body review that the quality and / or product management system is in accordance with what is included in the technical documentation through visits to the manufacturer with certain periodicity.

NUESTRA AMPLIA EXPERIENCIA EN FABRICACIÓN DE EQUIPOS DE FRÍO A NIVEL MUNDIAL Y CUMPLIENDO CON LAS ESPECIFICACIONES O REQUERIMIENTOS DE CALIDAD DE DIFERENTES MERCADOS, HACE QUE PUEDES CONFIAR EN INFRICO MEDCARE.

OUR EXTENSIVE EXPERIENCE AS A WORLDWIDE MANUFACTURER OF COOLING EQUIPMENT AND THE SPECIFICATIONS OR QUALITY REQUIREMENTS OF DIFFERENT MARKETS THAT WE COMPLY WITH, ENSURES YOU CAN RELY ON INFRICO MEDCARE.

GAMA HEALTH CARE PLUS

La gama Health CARE PLUS de nuestros equipos para bancos de sangre está diseñada de acuerdo a la **DIN 58371**, teniendo en cuenta la sensibilidad del producto almacenado y garantizando su seguridad. Ofrece modelos desde los 170L a los 1400L, disponibles con puertas ciega o de cristal y con el interior en acero inoxidable.

HEALTH CARE PLUS SERIES

The Health CARE PLUS series of our blood bank equipment is designed in agreement with **DIN 58371**, taking into account the sensitivity of the stored product and ensuring its safety. It offers models from 170L to 1400L, available with solid or glass doors and stainless steel interior.



BBTR17S / 170 L

Pág. 44



BBTR25S / 250 L



BBTR40S / 400 L



BBTR70S / 700 L

Pág. 46



BBTR140S / 1400 L



BBTR17G / 170 L

Pág. 44



BBTR25G / 250 L



BBTR40G / 400 L



BBTR70G / 700 L

Pág. 46



BBTR140G / 1400 L

CONTROLADORES DE TEMPERATURA / TEMPERATURE CONTROLLER





DISPLAY:
Precisión de 0,1°C.

DISPLAY:
Accuracy of 0.1°C.

CONTROL PRECISO:
Sondas PT1000

PRECISE CONTROL:
PT1000 probes

ESTABILIDAD Y UNIFORMIDAD:
Rango de estabilidad de producto de aproximadamente ±1°C y de uniformidad de temperatura en producto menor de ±2°C.

STABILITY AND UNIFORMITY:
Product stability range of approximately ±1°C and product uniformity temperature less than ±2°.



5 TIPOS DE ALARMAS ÓPTICAS Y ACÚSTICAS
Bajada o subida de temperatura, fallo de alimentación, fallo de sonda, batería descargada y puerta abierta

5 TYPES OF OPTICAL AND ACOUSTIC ALARMS
Temperature rise or fall, power failure, probe failure, low battery and open door



DATALOGGER
Registro de temperaturas e histórico de alarmas

DATALOGGER
Temperature log and alarm history

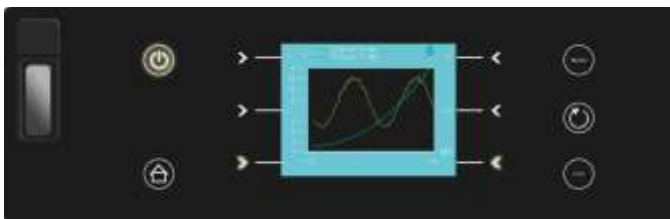

INFORMACIÓN DETALLADA DEL EQUIPO
Interfaz gráfica

DETAILED EQUIPMENT INFORMATION
Graphic interface

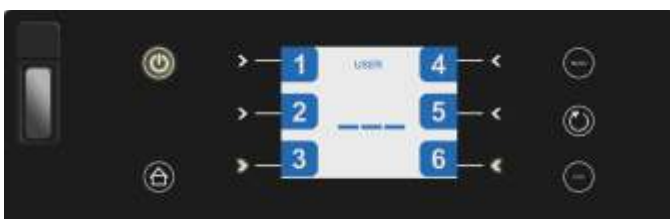

CONTRASEÑA NUMÉRICA
Sistema de control protegido con contraseña numérica

LOCK CODE
Lock code to access the control system

PHARMA

1

HEALTH

2

LAB

3

4

5

6

7

8



CARACTERÍSTICAS GENERALES / GENERAL FEATURES



CONTROLADOR DIGITAL PLUS

En todos los modelos de la gama Health CARE PLUS

DIGITAL PLUS CONTROLLER

In all models of Health CARE PLUS series



CERRADURA / SENSOR DE PUERTA

Todos nuestros equipos disponen de cerraduras y sensores de puerta abierta, para garantizar la seguridad de los productos almacenados, controlando el tiempo de apertura y el funcionamiento de los ventiladores.

LOCK / DOOR SENSOR

All our equipment has locks and open door sensors, to guarantee the security of the stored products by controlling opening time and fans functioning.



ILUMINACIÓN LED

El uso de iluminación LED reduce el consumo energético del equipo y mejora la homogeneidad de la temperatura en el interior.

LED LIGHTING

The use of LED lighting reduces the energy consumption and improves the homogeneity of the temperature inside the cabinet.

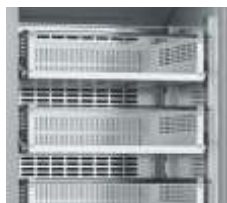

CAJONES FLEXIBLES

Nuestro sistema de cajones con frontales en policarbonato ofrece una total visibilidad del producto almacenado. Permite ajustar la posición de los mismos y variar su número o complementarlos con separadores. Esto proporciona una comodidad en el almacenamiento de bolsas de sangre o sus derivados, ajustando el equipo a sus necesidades.

FLEXIBLE DRAWERS

Our system of drawers with polycarbonate fronts allows a total visibility of the stored product. Position adjustments and its number variation or the complementing of dividers are allowed in the system. This provides the fitting of the equipment in accordance to your needs and storage comfort of blood bags or their derivatives.



ESTILO DE PUERTAS

En todos nuestros equipos existe la posibilidad de elegir entre puerta ciega o de cristal. Todas nuestras puertas son abatibles y reversibles.

DOOR STYLE

It is possible to choose solid or glass doors in our whole range. All our doors are hinged and reversible.



BURLETE DE ARPÓN PARA UN CAMBIO RÁPIDO Y FÁCIL

Es ideal para mantener una higiene óptima y para facilitar los trabajos de mantenimiento.

EASY REMOVABLE DOOR GASKET

It is ideal to maintain optimal hygiene and facilitate maintenance work.



AMPLIOS RADIOS

Los interiores presentan amplios radios en las esquinas, que facilitan su limpieza.

ROUNDED CORNERS

The interiors have rounded corners, which facilitate their cleaning.



INTERIOR EN ACERO INOXIDABLE
STAINLESS STEEL INTERIOR



SONDA DE SIMULACIÓN DE PRODUCTO

La sonda del controlador viene encapsulada en líquido para simular la temperatura interna del producto.

PRODUCT TEMPERATURE SIMULATION PROBE

The controller is equipped with a probe immersed in reference fluid to simulate internal product temperature.

SONDA DE REGULACIÓN EN AIRE

Además de la sonda de simulación de producto, los equipos de banco de sangre disponen de una sonda en aire con la que se regula la temperatura del equipo, aumentando la seguridad del mismo.

AIR REGULATION PROBE

In addition to the product temperature simulation probe, the blood bank equipment is regulated through an air temperature probe increasing safety in temperature readings.

TERMOSTATO DIGITAL ANTICONGELACIÓN

Este dispositivo imposibilita al producto a bajar su temperatura por debajo de +2°C.

FREEZING PROTECTION ELECTRONIC CONTROLLER

Safety thermostat prevents the temperature dropping below +2°C.

BATERÍA

Permite mantener el registro de temperatura y alarmas en el caso de fallo de alimentación

BATTERY

Allows the maintenance of temperature and alarms register in case of a power failure.

BANDEJA EVAPORATIVA

Nuestros equipos llevan incorporada una bandeja para evaporar de manera automática el agua del desescarche.

EVAPORATION PAN

Our equipment has a built-in tray to evaporate automatically defrosted water.

DESESCARCHES AUTOMÁTICOS INTELIGENTES

Nuestros equipos cuentan con desescarche automático, para asegurar una refrigeración uniforme en el tiempo y menos mantenimiento. Además, el equipo analiza su funcionamiento y realiza los desescarches solo cuando es necesario para mejorar la estabilidad de la temperatura.

ADVANCED DEFROST SYSTEM

Built-in to ensure uniform cooling over time and to facilitate maintenance. In addition, the equipment analyses its operation and only defrosts when it is necessary, to improve the stability of the temperature.



RUEDAS / PATAS REGULABLES / REGULADORES DE ALTURA

En todos nuestros armarios existe la posibilidad de ser equipados con ruedas para facilitar el desplazamiento y la limpieza.

CASTERS / ADJUSTABLE LEGS / HEIGHT REGULATORS In our whole range, there is a possibility to incorporate casters to facilitate displacement and cleaning.

PHARMA

1

HEALTH

2

LAB

3

4

5

6

7

8



 **First Aid**





PHARMA

1

HEALTH

2

LAB

3

4

5

6

7

8





ARMARIO DE REFRIGERACIÓN HEALTH CARE PLUS / HEALTH CARE PLUS REFRIGERATOR

DIN 58371



* Pruebas realizadas con una temperatura ambiente de +25°C / Measured at +25°C ambient temperature and

GAMA SERIES	Health CARE PLUS	Health CARE PLUS	Health CARE PLUS	Health CARE PLUS	Health CARE PLUS	Health CARE PLUS
MODELO MODEL	BBTR17S	BBTR17G	BBTR25S	BBTR25G	BBTR40S	BBTR40G
Rango Tª Temperature range (°C)	+2 / +6					
Capacidad Nominal (litros) Nominal Capacity (litres)	170	170	250	250	400	400
Medidas Exterior [mm] L x P x A Exterior dimensions [mm] W x D x H	670 x 670 x 1293	670 x 669 x 1293	670 x 673 x 1538	670 x 669 x 1538	670 x 673 x 1963	670 x 672 x 1963
Medidas Interior [mm] L x P x A Interior dimensions [mm] W x D x H	568 x 471 x 668	568 x 504 x 668	568 x 484 x 913	568 x 504 x 913	568 x 484 x 1338	568 x 504 x 1338
Claro de puerta [mm] L x A Door opening [mm] W x H	568 x 610	568 x 610	568 x 855	568 x 855	568 x 1280	568 x 1280
Espesor Aislamiento [mm] Insulation thickness [mm]	50					
Acabado Exterior Exterior finishing	Acero galvanizado plastificado blanco White plastic coated galvanised steel					
Acabado Interior Interior finishing	Acero Inoxidable Stainless steel					
Nº Cajones Drawers Number	3	3	4	4	6	6
Dimensiones Cajón [mm] L x P Drawer Size [mm] W x D	497 x 439					
Número de bolsas de sangre Blood bags capacity	132	132	176	176	264	264
Material Cajones Drawers Material	Acero Inoxidable Stainless steel					
Intercambiabilidad de Estantes/Cajones Interchangeable Shelves/Drawers	Si Yes					
Tipo de Puerta Door Type	Ciega Solid	Cristal Glass	Ciega Solid	Cristal Glass	Ciega Solid	Cristal Glass
Cerradura Lock	Si Yes					
Salida USB USB Port	Si Yes					
Datalogger Datalogger	Si Yes					
Batería Battery	Si Yes					
Sonda simulación producto Product temperature simulation probe	Si Yes					
Sonda de temperatura ambiente Interior room temperature probe	Si Yes					
Termostato anticongelación Freezing protection controller	Si Yes					
Tipo de Controlador Controller type	Digital Plus					
Tipo de Refrigerante Refrigerant type	R134a					
Potencia Eléctrica [W] Electric power [W]	281	290	346	360	356	360
Tensión/Frecuencia [V / Hz] Voltage/Frequency [V / Hz]	230 / 50					
Peso [kg] Weight [kg]	91	96	119	132	145	156

Nos reservamos el derecho a modificar las especificaciones técnicas y constructivas sin previo aviso.

We reserve the right to modify technical and construction specifications without prior notice.



BBTR17

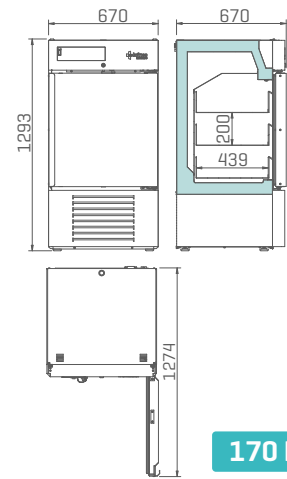

BBTR25

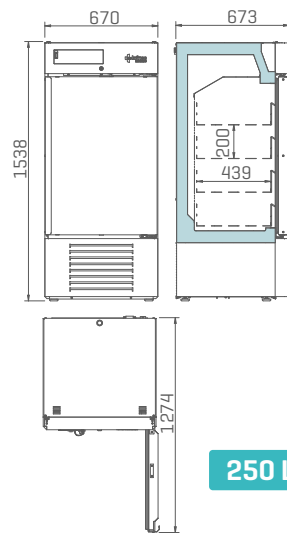

BBTR40

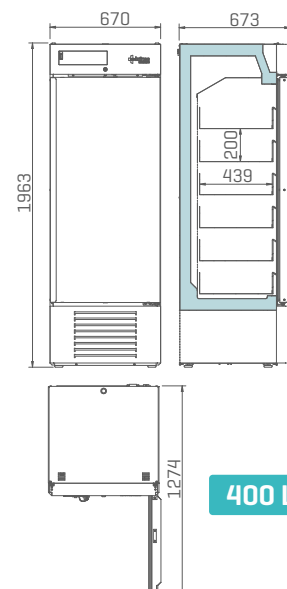

PHARMA

1

HEALTH

2

LAB

3

4

5

6

7

8



ARMARIO DE REFRIGERACIÓN HEALTH CARE PLUS / HEALTH CARE PLUS REFRIGERATOR

DIN 58371



* Pruebas realizadas con una temperatura ambiente de +25°C
* Measured at +25°C ambient temperature and

GAMA SERIES	Health CARE PLUS	Health CARE PLUS	Health CARE PLUS	Health CARE PLUS
MODELO MODEL	BBTR70S	BBTR70G	BBTR140S	BBTR140G
Rango T° Temperature range [°C]	+2 / +6			
Capacidad Nominal (litros) Nominal Capacity [litres]	700	700	1400	1400
Medidas Exterior [mm] L x P x A Exterior dimensions [mm] W x D x H	687 x 826 x 2132	687 x 826 x 2132	1384 x 820x 2131	1384 x 820 x 2131
Medidas Interior [mm] L x A Interior dimensions [mm] W x H	575 x 643 x 1349	575 x 662 x 1349	1277 x 643 x 1349	1277 x 622 x 1349
Claro de puerta [mm] Door opening [mm]	575 x 1488			
Espesor Aislamiento [mm] Insulation thickness [mm]	55			
Acabado Exterior Exterior finishing	Acero galvanizado plastificado blanco White plastic coated galvanised steel			
Acabado Interior Interior finishing	Acero Inoxidable Stainless steel			
N° Cajones Drawers Number	6	6	12	12
Dimensiones Cajón [mm] L x P Drawer Size [mm] W x D	497 x 593	497 x 593	497 x 593	497 x 593
N° bolsas de sangre Blood bags capacity	360	360	720	720
Material Cajones Drawers Material	Acero Inoxidable Stainless steel			
Intercambiabilidad de Estantes/Cajones Interchangeable Shelves/Drawers	Si Yes			
Tipo de Puerta Door Type	Ciega Solid	Cristal Glass	Ciega Solid	Cristal Glass
Cerradura Lock	Si Yes			
Salida USB USB Port	Si Yes			
Datalogger Datalogger	Si Yes			
Batería Battery	Si Yes			
Sonda simulación producto Product temperature simulation probe	Si Yes			
Sonda simulación producto Product temperature simulation probe	Si Yes			
Termostato anticongelación Freezing protection controller	Si Yes			
Tipo de Controlador Controller type	Digital Plus			
Tipo de Refrigerante Refrigerant type	R134a			
Potencia Eléctrica [W] Electric power [W]	430	460	590	645
Tensión/Frecuencia [V / Hz] Voltage/Frequency [V / Hz]	230 / 50			
Peso [kg] Weight [kg]	173	189	251	287

Nos reservamos el derecho a modificar las especificaciones técnicas y constructivas sin previo aviso.

We reserve the right to modify technical and construction specifications without prior notice.



BBTR70

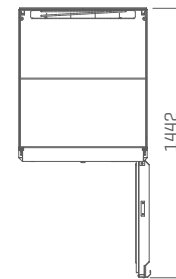
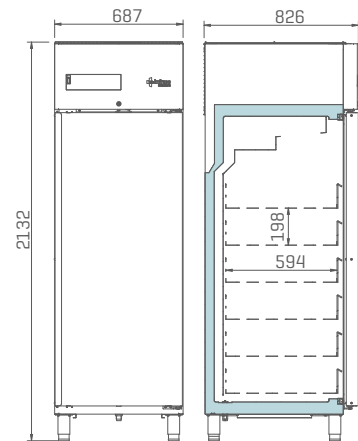

700 L



BBTR140

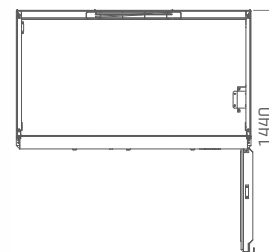
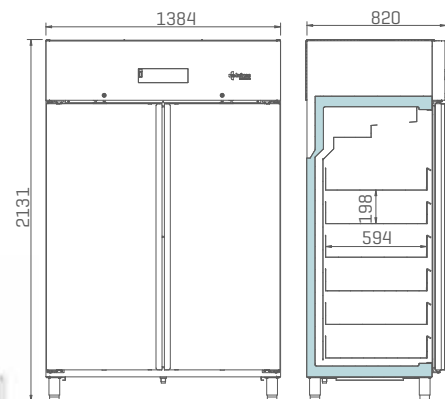

1400 L



40

Infrico

40

Infrico

4.0

Infrico

ULF -66°C

LAB CARE



Los equipos de refrigeración y congelación actuales tienen que garantizar a sus usuarios ante todo la seguridad y estabilidad térmica. Por este motivo los aparatos de la línea Lab CARE disponen de múltiples funciones para conservar todo tipo de productos sensibles. Entre ellos muestras, diferentes reactivos, células, hemoderivados o diferentes productos biológicos...

Debido al posible gran valor de los productos almacenados, los equipos de Infrico Medcare ofrecen unas características bastante más extensas que los equipos de uso doméstico o los utilizados en el canal HORECA.

Nuestra gama de refrigeradores y congeladores específicos para diferentes tipos de laboratorios está diseñada para mantener una temperatura homogénea de +2°C a +8 °C en refrigeradores y de -15°C a -86°C en los equipos de baja temperatura.

Es muy importante para los laboratorios de hoy una adecuada elección de los equipos de refrigeración y congelación, puesto que de la correcta conservación de las muestras depende la calidad de los resultados.

Today's refrigeration and freezing equipment must guarantee their users, above all, safety and thermal stability. For this reason, the Lab CARE series offers multiple functions to conserve all kinds of sensitive products. Among them samples, different reagents, cells, blood or biological products...

Due to the possible great value of the stored products, the Infrico Medcare equipment provides much more extensive characteristics than the equipment of domestic use or hotel and restaurant sector.

Our range of specific refrigerators and freezers for different types of laboratories is designed to maintain a homogeneous temperature of +2°C to +8°C in refrigerators and -15°C to -86°C in low temperature cabinets.

The right choice of refrigeration and freezing equipment is very important for today's laboratories, because the correct conservation affects the quality of the results.

Nosotros CUIDAMOS tus artículos más valiosos como, por ejemplo:

- Anticuerpos
- Patrones
- Bacterias o virus
- Células
- Medios de cultivos
- Citocinas
- Enzimas
- Productos biológicos
- Proteínas
- Hemoderivados
- Kits de pruebas de reactivos
- Cultivos
- Soportes de tejidos
- Muestras clínicas
- Principios activos
- Reactivos
- Etc.

We care about your most valuable products such as:

- Antibodies
- Patterns
- Bacteria or virus
- Derived Cells
- Cell culture media
- Cytokines
- Enzymes
- Biologicals
- Proteins
- Blood products
- Reagent Test Kits
- Cultures
- Tissue slides
- Clinical samples
- Active substances
- Reagents
- Etc.

PHARMA

1

HEALTH

2

LAB

3

4

5

6

7

8

NUESTRA AMPLIA EXPERIENCIA EN FABRICACIÓN DE EQUIPOS DE FRÍO A NIVEL MUNDIAL Y CUMPLIENDO CON LAS ESPECIFICACIONES O REQUERIMIENTOS DE CALIDAD DE DIFERENTES MERCADOS, HACE QUE PUEDES CONFIAR EN INFRICO MEDCARE.

OUR EXTENSIVE EXPERIENCE AS A WORLDWIDE MANUFACTURER OF COOLING EQUIPMENT AND THE SPECIFICATIONS OR QUALITY REQUIREMENTS OF DIFFERENT MARKETS THAT WE COMPLY WITH, ENSURES YOU CAN RELY ON INFRICO MEDCARE.

REFRIGERACIÓN

REFRIGERATION

GAMA LAB CARE

LAB CARE SERIES



La GAMA Lab CARE está compuesta de diferentes modelos de armarios refrigerados para adaptarnos a cualquier espacio o necesidad. De esta manera disponemos de modelos sobre encimera, bajo encimera y verticales, con volúmenes desde los 70 a los 360 litros. Todos los modelos están disponibles con puerta ciega o de cristal y opcionalmente con el acabado en acero inoxidable.

LAB CARE Series is composed of different models of refrigerated cabinets to adapt to any space or need. In such a way we have countertop, underbench or upright versions available with model range from 70 to 360 litres. Solid or glass doors are available and stainless steel finish as an option.



LER07S / 70 L

LER15S / 150 L

LER36S / 360 L

LER07G / 70 L

LER15G / 150 L

LER36G / 360 L

Pág. 58



LTR17SD / 170 L

LTR25SD / 250 L

LTR40SD / 400 L

LTR50SD / 500 L

LTR65SD / 650 L

LTR80SD / 800 L

LTR130SD / 1300 L

Pág. 60

Pág. 62

Pág. 64



LTR17GD / 170 L

LTR25GD / 250 L

LTR40GD / 400 L

LTR50GD / 500 L

LTR65GD / 650 L

LTR80GD / 800 L

LTR130GD / 1300 L

Pág. 60

Pág. 62

Pág. 64



BAJA TEMPERATURA

LOW TEMPERATURE

GAMA LAB CARE

LAB CARE SERIES



En esta gama de armarios de baja temperatura disponemos de modelos desde 150 litros hasta 1300 litros en rangos de -10°C hasta -25°C de temperatura, incluyendo un modelo bajo encimera.

In this series of low temperature cabinets in ranges from -10°C to -25°C, we have models from 150 to 1300 litres, including an undercounter model.

-10°C / -25°C



LEF15S / 150 L

Pág. 66



LTF25SD / 250 L



LTF40SD / 400 L

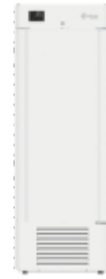

Estático / Static
LTF43SD / 430 L

Pág. 68



Estático / Static
LEF60S / 600 L

-10°C / -25°C

+2°C / +8°C
-10°C / -25°C



LTF65SD / 650 L

Pág. 70



LTF65GD / 650 L



LTF80SD / 800 L



LTF130SD / 1300 L



LTRF130SD / 1300 L Mixto / Dual Temp.

Pág. 70

ULTRA BAJA TEMPERATURA

ULTRA LOW TEMPERATURE

GAMA LAB CARE PLUS

LAB CARE PLUS SERIES



En esta gama de armarios de ultra baja temperatura, en rangos de -20°C hasta -40°C, disponemos de modelos desde 250 hasta 700 litros.

In this series of low temperature cabinets in ranges from -20°C to -40°C, we have models from 250 to 700 litres.

-20°C / -40°C



LEUF60S* / 600 L

Pág. 72



LTUF25S / 250 L



LTUF40S / 400 L



LTUF65S / 650 L

Pág. 74



LTUF80S / 800 L



ULF50040 / 500 L



ULF70040 / 700 L

*Gama Lab Care / Lab Care Series

ULTRA BAJA TEMPERATURA ULTRA LOW TEMPERATURE

GAMA LAB CARE PLUS

LAB CARE PLUS SERIES



En el rango de temperatura de -40°C a -86°C , disponemos de modelos desde 110 hasta 800 litros, incluyendo modelos bajo encimera y verticales.

In ranges from -40°C to -86°C , we have models from 110 to 800 litres, including an undercounter and vertical freezers.

$-40^{\circ}\text{C} / -86^{\circ}\text{C}$



ULF11086 / 110 L

Pág. 80



ULF40086 / 400 L



ULF50086 / 500 L



ULF70086 / 700 L

Pág. 82



ULF80086 / 800 L

GAMA LAB CARE PLUS

LAB CARE PLUS SERIES



También disponemos de dos modelos arcones de ultra congelación de 500 y 700 litros respectivamente de capacidad.

We also have two models ultra low chest freezer of 500 and 700 litres respectively.

$-40^{\circ}\text{C} / -86^{\circ}\text{C}$



CLF50086 / 500 L

Pág. 84



CLF70086 / 700 L





CARACTERÍSTICAS COMPARATIVAS / COMPARATIVE FEATURES

CARACTERÍSTICAS CHARACTERISTICS	DOMÉSTICO DOMESTIC USE	INDUSTRIAL INDUSTRIAL	INFRICO MEDCARE	INFRICO MEDCARE PLUS	VENTAJAS ADVANTAGES
CONSTRUCTIVAS CONSTRUCTION					
Cuerpo robusto Robust structure	-	●	●	●	Durabilidad de uso Durability of use
Puertas con cerradura Doors with lock	-	●	●	●	Control de acceso y seguridad del producto almacenado Access control and security of stored product
Puertas con sistema autocierre Self-closing doors	-	●	●	●	Prevención de la apertura accidental Prevention of accidental opening
Bisagras y burletes de alta calidad High quality hinges and door gaskets	-	●	●	●	Durabilidad de uso y estabilidad de temperatura Durability of use and temperature stability
Ruedas de alta resistencia con sistema de frenado High resistance casters with braking system	-	○	○	○	Fácil desplazamiento de los equipos Easy equipment mobility
Flujo de aire dirigido Directed airflow	-	-	●	●	Uniformidad de temperatura Temperature uniformity
Puertas de cristal templado de tres capas Three-layer tempered glass doors	-	-	●	●	Mejor aislamiento. Rápida comprobación y preselección del contenido Better insulation. Quick verification and content pre-selection
Pasamuros Access ports	-	-	○	●/○	Posibilidad de conexión de los equipos externos o sondas Possibility of connecting external equipment or probes
FUNCIONAMIENTO Y CONTROL OPERATION AND CONTROL					
Control por microprocesador Microprocessor controlled	-	●	●	●	Control de la temperatura más exacto Exact temperature control
Pantalla táctil gráfica Graphic Touch screen	-	-	●	●	Mayor información al usuario More information for the user
Rango uniformidad de temperatura ±2°C - ±0,5°C Uniformity range ±2°C - ±0,5°C	-	●	●	●	Almacenamiento seguro a temperatura uniforme Safe storage at uniform temperature
Rango estabilidad de temperatura aprox. 1°C Temperature stability range of aprox. 1°C	-	●	●	●	Mantenimiento de la temperatura de la cámara interior Maintaining the temperature of the inner chamber
Sistema de refrigeración profesional Professional refrigeration system	-	●	●	●	Uniformidad y estabilidad de temperatura Temperature uniformity and stability
Diferentes tipos de alarmas Different types of alarms	-	●	●	●	Seguridad ante posibles riesgos Safety against possible risks
Control de ajustes restringido Restricted settings control	-	-	-	●	Garantía de temperatura programada mediante código de seguridad Temperature guarantee programmed by security code
Desescarche automático Automatic defrost	●	●	●	●	Refrigeración uniforme y menos mantenimiento Uniform cooling and minimal maintenance
Puerto USB USB port	-	-	○	●	Fácil y cómoda descarga de datos Easy and convenient data download
Datalogger	-	-	○	●	Registro constante de temperaturas, alarmas, número de aperturas de puerta, desescarches... Constant recording of temperatures, alarms, number of door openings, defrosts ...
Sonda de simulación de temperatura de producto Product temperature simulation probe	-	-	○	○	Fiabilidad sobre la temperatura del producto almacenado Reliability of stored product temperature
Batería Battery	-	-	○	○	Permite no interrumpir los registros Allows no interruption of datalogging
SERVICIO TÉCNICO TECHNICAL SERVICE					
Asistencia técnica rápida y segura Quick and safe technical support	○	●	●	●	Tranquilidad absoluta Complete peace of mind
Asesoramiento técnico Technical consulting	○	●	●	●	Apoyo de los especialistas cualificados Qualified specialists support
Contratos de mantenimiento Maintenance contracts	-	-	●	●	Revisiones periódicas para mantener las condiciones óptimas de los equipos Periodic reviews to keep optimal equipment conditions
Servicios de validación Validation service	-	-	●	●	Aseguran conformidad con las normativas Ensure regulatory compliance

● ESTANDAR / STANDARD

○ OPCIONAL / OPTIONAL

- NO DISPONIBLE / NOT AVAILABLE



CARACTERÍSTICAS GENERALES / GENERAL FEATURES



CONTROLADOR DIGITAL o CONTROLADOR DIGITAL PLUS

¡Elige según tus necesidades!

DIGITAL CONTROLLER or DIGITAL PLUS CONTROLLER

Choose according to your needs!



CERRADURA / SENSOR DE PUERTA

Todos nuestros equipos disponen de cerraduras y sensores de puerta abierta, para garantizar la seguridad de los productos almacenados, controlando el tiempo de apertura y el funcionamiento de los ventiladores.

LOCK / DOOR SENSOR

All our equipment has locks and open door sensors, to guarantee the security of the stored products by controlling opening time and fans functioning.



ILUMINACIÓN LED

El uso de iluminación LED reduce el consumo energético del equipo y mejora la homogeneidad de la temperatura en el interior.

LED LIGHTING

The use of LED lighting reduces the energy consumption and improves the homogeneity of the temperature inside the cabinet.



ALMACENAMIENTO FLEXIBLE

Nuestro nuevo sistema de estantes/cajones permite ajustar la posición de los mismos, variar su número, cambiar estantes por cajones y viceversa. Esto proporciona el ajuste del equipo a sus necesidades y comodidad de almacenamiento de medicamentos o vacunas de diferentes tamaños.

FLEXIBLE STORAGE SOLUTIONS

Our new shelf / drawer system allows you to adjust their position, vary their number, change shelves for drawers and vice versa or compliment them with divisors. This provides the fit of the equipment to your needs and storage convenience of medications or vaccines of different sizes.



ESTILO DE PUERTAS

En todos nuestros equipos existe la posibilidad de elegir entre puerta ciega o de cristal. Todas nuestras puertas son abatibles y reversibles.

DOOR STYLE

It is possible to choose solid or glass doors in our whole range. All our doors are hinged and reversible.



BURLETE DE ARPÓN PARA UN CAMBIO RÁPIDO Y FÁCIL

Es ideal para mantener una higiene óptima y para facilitar los trabajos de mantenimiento.

EASY REMOVABLE DOOR GASKET

It is ideal to maintain optimal hygiene and facilitate maintenance work.



AMPLIOS RADIOS

Los interiores presentan amplios radios en las esquinas, que facilitan su limpieza.

ROUNDED CORNERS

The interiors have rounded corners, which facilitate their cleaning.



CUADRO DE CONTROL ACCESIBLE

Todos los componentes del control electrónico están en una posición segura y de fácil acceso.

ACCESIBLE CONTROL PANEL

Safe position and easy access to all electronic control components.



ACABADOS DISPONIBLES

Todos nuestros modelos están disponibles con acabado en color blanco o en acero inoxidable.

AVAILABLE FINISHES

All our models are available in white or stainless steel finish.

BANDEJA EVAPORATIVA

Nuestros equipos llevan incorporada una bandeja para evaporar de manera automática el agua del desescarche.

EVAPORATION PAN

Our equipment has a built-in tray to evaporate automatically defrosted water.

DESESCARCHES AUTOMÁTICOS INTELIGENTES

Nuestros equipos cuentan con desescarche automático, para asegurar una refrigeración uniforme en el tiempo y menos mantenimiento. Además, el equipo analiza su funcionamiento y realiza los desescarches solo cuando es necesario para mejorar la estabilidad de la temperatura.

ADVANCED DEFROST SYSTEM

Built-in to ensure uniform cooling over time and to facilitate maintenance. In addition, the equipment analyses its operation and only defrosts when it is necessary, to improve the stability of the temperature.



RUEDAS / PATAS REGULABLES / REGULADORES DE ALTURA

En todos nuestros armarios existe la posibilidad de ser equipados con ruedas para facilitar el desplazamiento y la limpieza.

CASTERS / ADJUSTABLE LEGS / HEIGHT REGULATORS

In our whole range, there is a possibility to incorporate casters to facilitate displacement and cleaning.

PHARMA
1
HEALTH
2
LAB
3
4
5
6
7
8



Infrico
medicare

90
90
BIOHAZARD
RADIOACTIVE

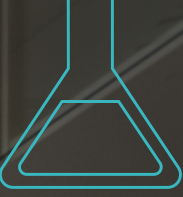

PHARMA

1

HEALTH

2

LAB

3

4

5

6

7

8



ARMARIO DE REFRIGERACIÓN LAB CARE / LAB CARE REFRIGERATOR



* Pruebas realizadas con una temperatura ambiente de +25°C
* Measured at +25°C ambient temperature and

GAMA SERIES	Lab CARE	Lab CARE	Lab CARE	Lab CARE	Lab CARE	Lab CARE
MODELO MODEL	LER07S	LER07G	LER15S	LER15G	LER36S	LER36G
Rango T* Temperature range (°C)	+2 / +8	+2 / +8	+2 / +8	+2 / +8	+2 / +8	+2 / +8
Capacidad Nominal (litros) Nominal Capacity (litres)	70	70	150	150	360	360
Medidas Exterior [mm] L x P x A Exterior dimensions [mm] W x D x H	445 x 526 x 818	445 x 508 x 818	600 x 637 x 823	600 x 628 x 823	620 x 634 x 1858	620 x 625 x 1851
Medidas Interior [mm] L x P x A Interior dimensions [mm] W x D x H	358 x 312 x 523	358 x 323 x 523	505 x 456 x 452	505 x 461 x 452	534 x 450 x 1448	534 x 460 x 1448
Claro de puerta [mm] L x A Door opening [mm] W x H	358 x 516	358 x 516	505 x 555	505 x 555	534 x 1441	534 x 1441
Espesor Aislamiento [mm] Insulation thickness [mm]	40	40	45	45	40	40
Acabado Exterior Exterior finishing	Acero galvanizado plastificado blanco White plastic coated galvanised steel					
Acabado Interior Interior finishing	Acero galvanizado plastificado blanco White plastic coated galvanised steel					
Nº Estantes Shelves Number	2	2	3	3	6	6
Dimensiones Estante [mm] L x P Shelf Size [mm] W x D	315 x 248	315 x 248	458 x 398	458 x 398	488 x 398	488 x 398
Material Estantes Shelves Material	Acero galvanizado con pintura Epoxi Epoxy coated galvanised steel					
Intercambiabilidad de Estantes/Cajones Interchangeable Shelves/Drawers	No	No	Si Yes	Si Yes	Si Yes	Si Yes
Tipo de Puerta Door Type	Ciega Solid	Cristal Glass	Ciega Solid	Cristal Glass	Ciega Solid	Cristal Glass
Cerradura Lock	Si Yes					
Salida USB USB Port	No					
Datalogger Datalogger	Opcional Optional					
Batería Battery	Opcional Optional					
Sonda simulación producto Product temperature simulation probe	Opcional Optional					
Sonda de temperatura ambiente Interior room temperature probe	Opcional Optional					
Termostato anticongelación Freezing protection controller	Opcional Optional					
Tipo de Controlador Controller type	Digital					
Tipo de Refrigerante Refrigerant type	R600a	R600a	R290	R290	R290	R290
Potencia Eléctrica [W] Electric power [W]	113	113	191	191	210	210
Tensión/Frecuencia [V / Hz] Voltage/Frequency [V / Hz]	230 / 50					
Peso [kg] Weight [kg]	40	43	57	60	108	119

Nos reservamos el derecho a modificar las especificaciones técnicas y constructivas sin previo aviso.

We reserve the right to modify technical and construction specifications without prior notice.



LER07

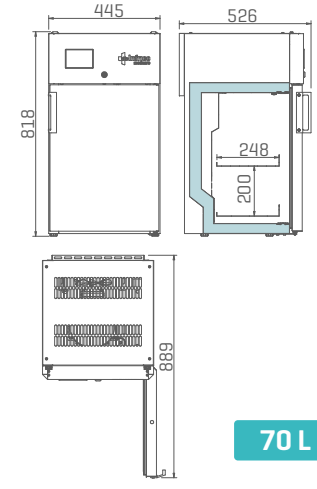

LER15

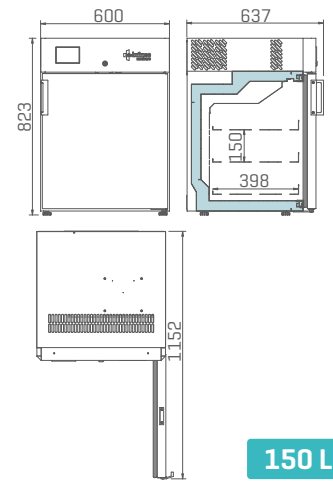

LER36

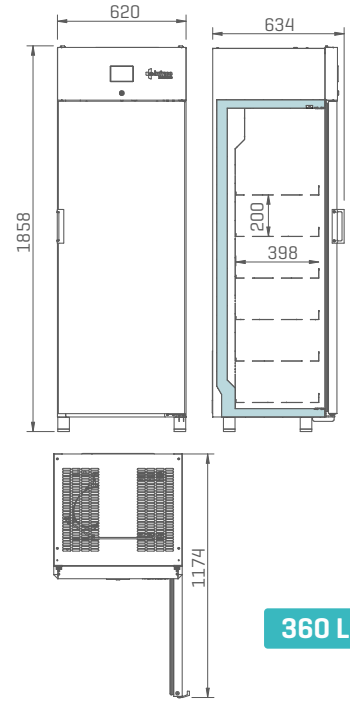

PHARMA	1
HEALTH	2
LAB	3
	4
	5
	6
	7
	8



ARMARIO DE REFRIGERACIÓN LAB CARE / LAB CARE REFRIGERATOR



GAMA SERIES	Lab CARE	Lab CARE	Lab CARE	Lab CARE
MODELO MODEL	LTR17SD	LTR17GD	LTR25SD	LTR25GD
Rango T* Temperature range (°C)	+2 / +8	+2 / +8	+2 / +8	+2 / +8
Capacidad Nominal (litros) Nominal Capacity (litres)	170	170	250	250
Medidas Exterior (mm) L x P x A Exterior dimensions (mm) W x D x H	670 x 673 x 1293	670 x 671 x 1293	670 x 670 x 1538	670 x 667 x 1538
Medidas Interior (mm) L x P x A Interior dimensions (mm) W x D x H	568 x 484 x 668	568 x 503 x 668	568 x 484 x 913	568 x 503 x 913
Claro de puerta (mm) L x A Door opening (mm) W x H	568 x 610	568 x 610	568 x 855	568 x 855
Espesor Aislamiento (mm) Insulation thickness (mm)	50	50	50	50
Acabado Exterior Exterior finishing	Acero galvanizado plastificado blanco White plastic coated galvanised steel			
Acabado Interior Interior finishing	Acero galvanizado plastificado blanco White plastic coated galvanised steel			
Nº Estantes Shelves Number	3	3	4	4
Dimensiones Estante (mm) L x P Shelf Size (mm) W x D	516 x 443	516 x 443	516 x 443	516 x 443
Material Estantes Shelves Material	Acero galvanizado con pintura Epoxi Epoxy coated galvanised steel			
Intercambiabilidad de Estantes/Cajones Interchangeable Shelves/Drawers	Si Yes			
Tipo de Puerta Door Type	Ciega Solid	Cristal Glass	Ciega Solid	Cristal Glass
Cerradura Lock	Si Yes			
Salida USB USB Port	No			
Datalogger Datalogger	Opcional Optional			
Batería Battery	Opcional Optional			
Sonda simulación producto Product temperature simulation probe	Opcional Optional			
Sonda de temperatura ambiente Interior room temperature probe	Opcional Optional			
Termostato anticongelación Freezing protection controller	Opcional Optional			
Tipo de Controlador Controller type	Digital			
Tipo de Refrigerante Refrigerant type	R290			
Potencia Eléctrica (W) Electric power (W)	183	188	186	194
Tensión/Frecuencia (V / Hz) Voltage/Frequency (V / Hz)	230 / 50			
Peso (kg) Weight (kg)	91	96	110	118

* Pruebas realizadas con una temperatura ambiente de +25°C
* Measured at +25°C ambient temperature and



LTR17

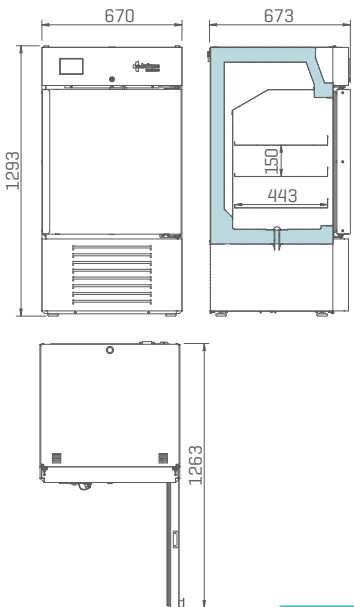

170 L



LTR25

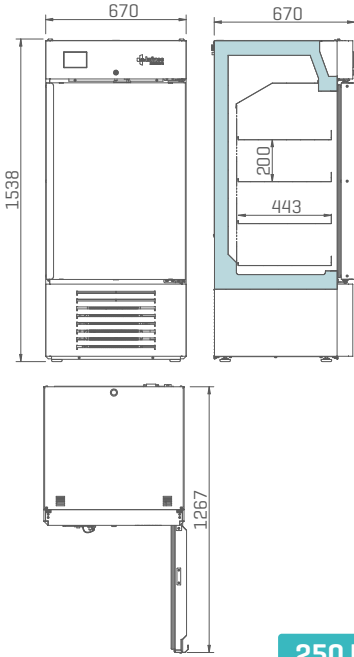

250 L

PHARMA
1
HEALTH
2
LAB
3
4
5
6
7
8



ARMARIO DE REFRIGERACIÓN LAB CARE / LAB CARE REFRIGERATOR



GAMA SERIES	Lab CARE	Lab CARE	Lab CARE	Lab CARE	Lab CARE	Lab CARE
MODELO MODEL	LTR40SD	LTR40GD	LTR50SD	LTR50GD	LTR65SD	LTR65GD
Rango T* Temperature range (°C)	+2 / +8	+2 / +8	+2 / +8	+2 / +8	+2 / +8	+2 / +8
Capacidad Nominal [litros] Nominal Capacity [litres]	400	400	500	500	650	650
Medidas Exterior [mm] L x P x A Exterior dimensions [mm] W x D x H	670 x 670 x 1963	670 x 670 x 1963	687 x 734 x 2018	687 x 734 x 2018	687 x 853 x 1955	687 x 853 x 1955
Medidas Interior [mm] L x P x A Interior dimensions [mm] W x D x H	568 x 484 x 1338	568 x 504 x 1338	577 x 525 x 1356	577 x 543 x 1356	534 x 633 x 1207	534 x 654 x 1207
Claro de puerta [mm] L x A Door opening [mm] W x H	568x1280	568x1280	577x1348	577x1348	534x1350	534x1350
Espesor Aislamiento [mm] Insulation thickness [mm]	50	50	55	55	75	75
Acabado Exterior Exterior finishing	Acero galvanizado plastificado blanco White plastic coated galvanised steel					
Acabado Interior Interior finishing	Acero galvanizado plastificado blanco White plastic coated galvanised steel			Acero Inoxidable Stainless steel		
Nº Estantes Shelves Number	7					
Dimensiones Estante [mm] L x P Shelf Size [mm] W x D	516 x 443	516 x 443	530x473	530x473	483 x 598	483 x 598
Material Estantes Shelves Material	Acero galvanizado plastificado blanco White plastic coated galvanised steel			Acero Inoxidable Stainless steel		
Intercambiabilidad de Estantes/Cajones Interchangeable Shelves/Drawers	Si Yes					
Tipo de Puerta Door Type	Ciega Solid	Cristal Glass	Ciega Solid	Cristal Glass	Ciega Solid	Cristal Glass
Cerradura Lock	Si Yes					
Salida USB USB Port	No					
Datalogger Datalogger	Opcional Optional					
Batería Battery	Opcional Optional					
Sonda simulación producto Product temperature simulation probe	Opcional Optional					
Sonda de temperatura ambiente Interior room temperature probe	Opcional Optional					
Termostato anticongelación Freezing protection controller	Opcional Optional					
Tipo de Controlador Controller type	Digital					
Tipo de Refrigerante Refrigerant type	R290					
Potencia Eléctrica [W] Electric power [W]	183	202	382	402	347	361
Tensión/Frecuencia [V / Hz] Voltage/Frequency [V / Hz]	230 / 50					
Peso [kg] Weight [kg]	138	145	150	158	165	175

* Pruebas realizadas con una temperatura ambiente de +25°C
* Measured at +25°C ambient temperature and



LTR40

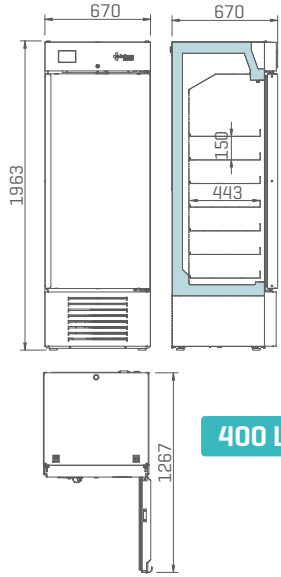

LTR50

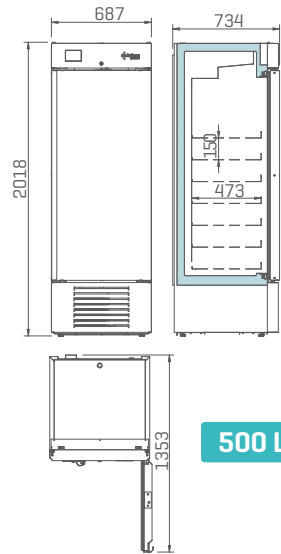

LTR65

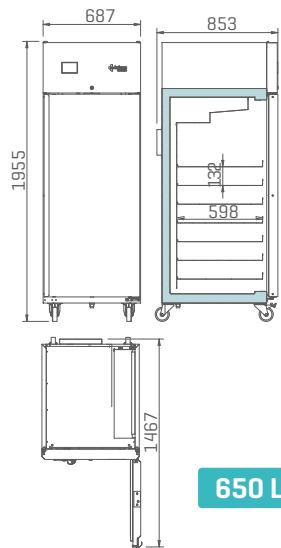

- PHARMA
- 1
- HEALTH
- 2
- LAB
- 3
- 4
- 5
- 6
- 7
- 8



ARMARIO DE REFRIGERACIÓN LAB CARE / LAB CARE REFRIGERATOR



* Pruebas realizadas con una temperatura ambiente de +25°C

GAMA SERIES	Lab CARE	Lab CARE	Lab CARE	Lab CARE
MODELO MODEL	LTR80SD	LTR80GD	LTR130SD	LTR130GD
Rango T° Temperature range [°C]	+2 / +8	+2 / +8	+2 / +8	+2 / +8
Capacidad Nominal [litros] Nominal Capacity [litres]	800	800	1300	1300
Medidas Exterior [mm] L x P x A Exterior dimensions [mm] W x D x H	797 x 985 x 1955	797 x 985 x 1955	1385 x 816 x 1955	1385 x 816 x 1955
Medidas Interior [mm] L x P x A Interior dimensions [mm] W x D x H	645 x 803 x 1388	645 x 823 x 1388	1234 x 688 x 1388	1234 x 702 x 1388
Claro de puerta [mm] L x A Door opening [mm] W x H	645 x 1350	645 x 1350	534 x 1350	534 x 1350
Espesor Aislamiento [mm] Insulation thickness [mm]	75			
Acabado Exterior Exterior finishing	Acero galvanizado plastificado blanco White plastic coated galvanised steel			
Acabado Interior Interior finishing	Acero Inoxidable Stainless steel			
Nº Estantes Shelves Number	7	7	14	14
Dimensiones Estante [mm] L x P Shelf Size [mm] W x D	595 x 745	595 x 745	483 x 598	483 x 598
Material Estantes Shelves Material	Acero Inoxidable Stainless steel			
Intercambiabilidad de Estantes/Cajones Interchangeable Shelves/Drawers	Si Yes			
Tipo de Puerta Door Type	Ciega Solid	Cristal Glass	Ciega Solid	Cristal Glass
Cerradura Lock	Si Yes			
Salida USB USB Port	No			
Datalogger Datalogger	Opcional Optional			
Batería Battery	Opcional Optional			
Sonda simulación producto Product temperature simulation probe	Opcional Optional			
Sonda de temperatura ambiente Interior room temperature probe	Opcional Optional			
Termostato anticongelación Freezing protection controller	Opcional Optional			
Tipo de Controlador Controller type	Digital			
Tipo de Refrigerante Refrigerant type	R290			
Potencia Eléctrica [W] Electric power [W]	347	361	354	386
Tensión/Frecuencia [V / Hz] Voltage/Frequency [V / Hz]	230 / 50			
Peso [kg] Weight [kg]	172	178	263	279

Nos reservamos el derecho a modificar las especificaciones técnicas y constructivas sin previo aviso.

We reserve the right to modify technical and construction specifications without prior notice.



LTR80

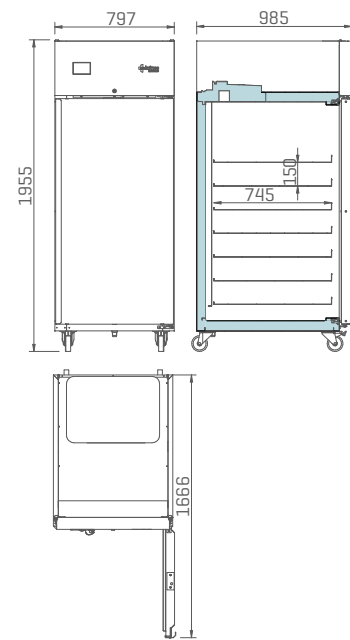

800 L



LTR130

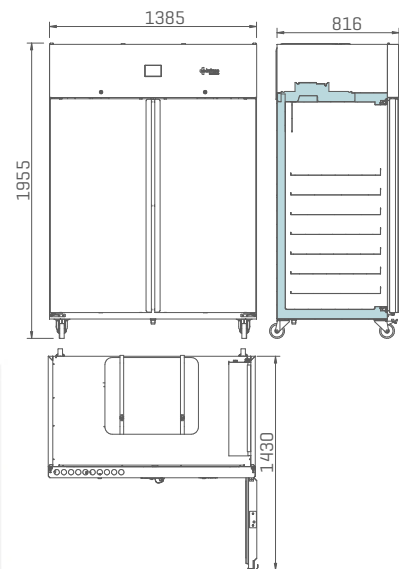

1300 L

PHARMA

1

HEALTH

2

LAB

3

4

5

6

7

8



ARMARIO DE CONGELACIÓN LAB CARE / LAB CARE FREEZER



GAMA SERIES	Lab CARE	Lab CARE	Lab CARE
MODELO MODEL	LEF15S	LTF25SD	LTF40SD
Rango Tª Temperature range [°C]	-10 / -25	-10 / -25	-10 / -25
Capacidad Nominal (litros) Nominal Capacity [litres]	150	250	400
Medidas Exterior [mm] L x P x A Exterior dimensions [mm] W x D x H	600 x 637 x 823	670 x 706 x 1538	670 x 706 x 1963
Medidas Interior [mm] L x P x A Interior dimensions [mm] W x D x H	505 x 456 x 452	568 x 468 x 913	520 x 484 x 1337
Claro de puerta [mm] L x A Door opening [mm] W x H	505 x 555	568 x 855	568 x 1280
Espesor Aislamiento [mm] Insulation thickness [mm]	45	75	75
Acabado Exterior Exterior finishing	Acero galvanizado plastificado blanco White plastic coated galvanised steel		
Acabado Interior Interior finishing	Acero galvanizado plastificado blanco White plastic coated galvanised steel		
Nº Estantes Shelves Number	3	4	7
Dimensiones Estante [mm] L x P Shelf Size [mm] W x D	458 x 398	470 x 443	470 x 443
Material Estantes Shelves Material	Acero galvanizado plastificado blanco White plastic coated galvanised steel		
Intercambiabilidad de Estantes/Cajones Interchangeable Shelves/Drawers	Sí Yes		
Tipo de Puerta Door Type	Ciega Solid		
Cerradura Lock	Sí Yes		
Salida USB USB Port	No		
Datalogger Datalogger	Opcional Optional		
Batería Battery	Opcional Optional		
Sonda simulación producto Product temperature simulation probe	No		
Sonda de temperatura ambiente Interior room temperature probe	Opcional Optional		
Tipo de Controlador Controller type	Digital		
Tipo de Refrigerante Refrigerant type	R290		
Potencia Eléctrica [W] Electric power [W]	249	326	477
Tensión/Frecuencia [V / Hz] Voltage/Frequency [V / Hz]	230 / 50		
Peso [kg] Weight [kg]	62	118	153

* Pruebas realizadas con una temperatura ambiente de +25°C
* Measured at +25°C ambient temperature and



LEF15

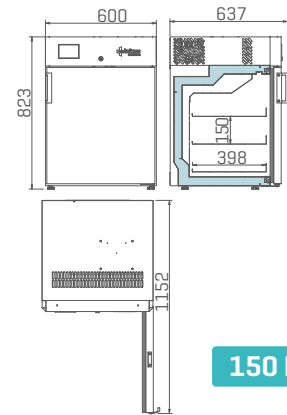

150 L



LTF25

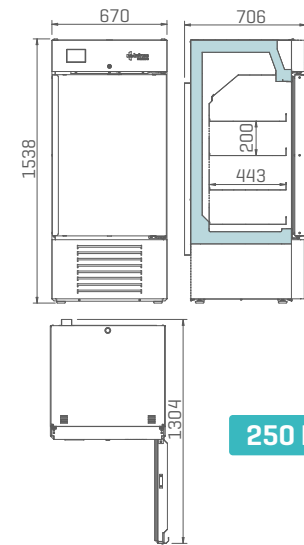

250 L



LTF40

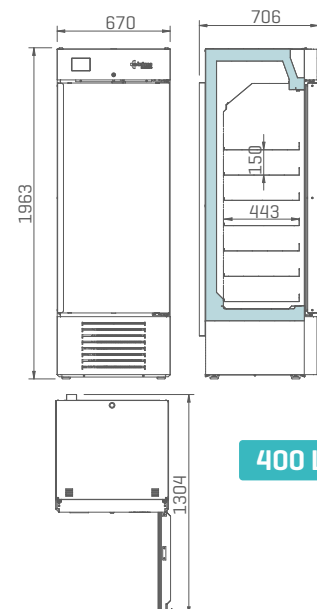

400 L

PHARMA	1
HEALTH	2
LAB	3
	4
	5
	6
	7
	8



ARMARIO DE CONGELACIÓN LAB CARE / LAB CARE FREEZER



GAMA SERIES	Lab CARE	Lab CARE
MODELO MODEL	LTF43SD (Static)	LEF60S (Static)
Rango T° Temperature range [°C]	-10 / -25	-10 / -25
Capacidad Nominal (litros) Nominal Capacity (litres)	430	600
Medidas Exterior (mm) L x P x A Exterior dimensions (mm) W x D x H	687 x 712 x 2018	750 x 772 x 1966
Medidas Interior (mm) L x P x A Interior dimensions (mm) W x D x H	577 x 540 x 1510	624 x 589 x 1594
Claro de puerta (mm) L x A Door opening (mm) W x H	577 x 1348	624 x 1557
Espesor Aislamiento (mm) Insulation thickness (mm)	50	60
Acabado Exterior Exterior finishing	Acero galvanizado plastificado blanco White plastic coated galvanised steel	Acero Inoxidable Stainless steel
Acabado Interior Interior finishing	Acero galvanizado plastificado blanco White plastic coated galvanised steel	Acero Inoxidable Stainless steel
N° Estantes/Contenedores Shelves/Containers Number	5 / -	6 / 13
Dimensiones Estantes (mm) L x P Shelf Size (mm) W x D	540 x 430	480 x 618
Material Estantes Shelves Material	Parrilla de alambre cromado Chrome-plated wire shelf	
Intercambiabilidad de Estantes/Cajones Interchangeable Shelves/Drawers	No	
Tipo de Puerta Door Type	Ciega Solid	
Cerradura Lock	Si Yes	
Salida USB USB Port	No	
Datalogger Datalogger	Opcional Optional	
Batería Battery	Opcional Optional	
Sonda simulación producto Product temperature simulation probe	No	
Sonda de temperatura ambiente Interior room temperature probe	Opcional Optional	
Tipo de Controlador Controller type	Digital	
Tipo de Refrigerante Refrigerant type	R290	
Potencia Eléctrica [W] Electric power [W]	415	327
Tensión/Frecuencia [V / Hz] Voltage/Frequency [V / Hz]	230 / 50	
Peso [kg] Weight [kg]	90	125

* Pruebas realizadas con una temperatura ambiente de +25°C
* Measured at +25°C ambient temperature and



LTF43 [Static]

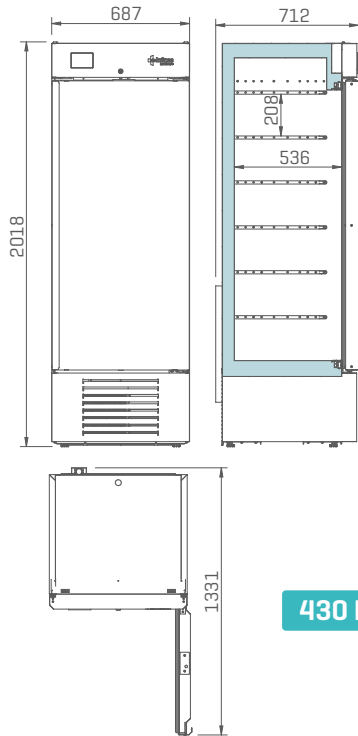

LEF60 [Static]

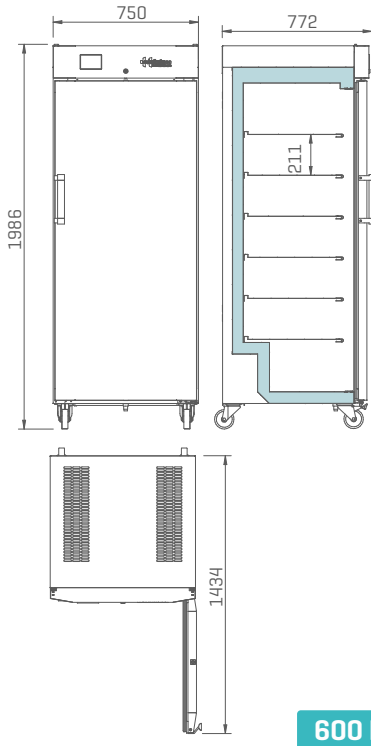

PHARMA
1
HEALTH
2
LAB
3
4
5
6
7
8



ARMARIO DE CONGELACIÓN LAB CARE / LAB CARE FREEZER



GAMA SERIES	Lab CARE	Lab CARE	Lab CARE	Lab CARE	Lab CARE
MODELO MODEL	LTF65SD	LTF65GD	LTF80SD	LTF130SD	LTRF130SD (DUAL TEMP.)
Rango Tª Temperature range [°C]	-10 / -25	-10 / -25	-10 / -25	-10 / -25	+2 / +8 ; -10 / -25
Capacidad Nominal [litros] Nominal Capacity [litres]	250	400	800	1300	1300
Medidas Exterior [mm] L x P x A Exterior dimensions [mm] W x D x H	687 x 853 x 1955	687 x 853 x 1955	797 x 981 x 1955	1385 x 853 x 1955	1385 x 853 x 1955
Medidas Interior [mm] L x P x A Interior dimensions [mm] W x D x H	534 x 633 x 1207	534 x 654 x 1207	645 x 803 x 1388	1234 x 680 x 1388	534+534 x 680 x 1388
Claro de puerta [mm] L x A Door opening [mm] W x H	534 x 1350	534 x 1350	645 x 1350	534 x 1350	534 x 1350
Espesor Aislamiento [mm] Insulation thickness [mm]	75				
Acabado Exterior Exterior finishing	Acero galvanizado plastificado blanco White plastic coated galvanised steel				
Acabado Interior Interior finishing	Acero Inoxidable Stainless steel				
Nº Estantes Shelves Number	7				
Dimensiones Estante [mm] L x P Shelf Size [mm] W x D	483 x 598	483 x 598	595 x 745	483 x 598	483 x 598
Material Estantes Shelves Material	Acero Inoxidable Stainless steel				
Intercambiabilidad de Estantes/Cajones Interchangeable Shelves/Drawers	Si Yes				
Tipo de Puerta Door Type	Ciega Solid	Cristal Glass	Ciega Solid		
Cerradura Lock	Si Yes				
Salida USB USB Port	No				
Datalogger Datalogger	Opcional Optional				
Batería Battery	Opcional Optional				
Sonda simulación producto Product temperature simulation probe	No				
Sonda de temperatura ambiente Interior room temperature probe	Opcional Optional				
Tipo de Controlador Controller type	Digital				
Tipo de Refrigerante Refrigerant type	R290				
Potencia Eléctrica [W] Electric power [W]	684	703	636	1024	1031
Tensión/Frecuencia [V / Hz] Voltage/Frequency [V / Hz]	230 / 50				
Peso [kg] Weight [kg]	147	165	180	279	262

* Pruebas realizadas con una temperatura ambiente de +25°C
* Measured at +25°C ambient temperature and

Nos reservamos el derecho a modificar las especificaciones técnicas y constructivas sin previo aviso.

We reserve the right to modify technical and construction specifications without prior notice.



LTF65

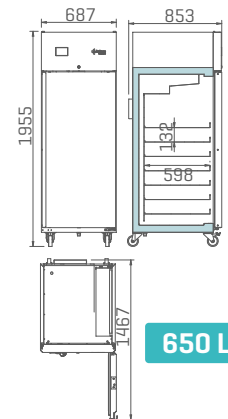

650 L



LTF80

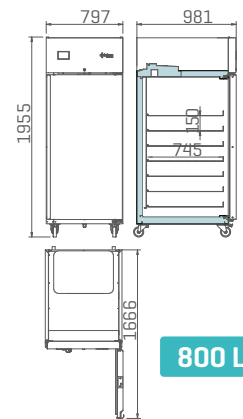

800 L



LTF130

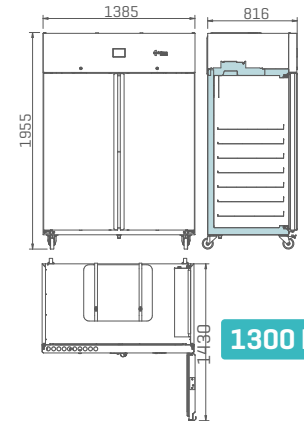

1300 L



LTRF130 [Dual Temperature]

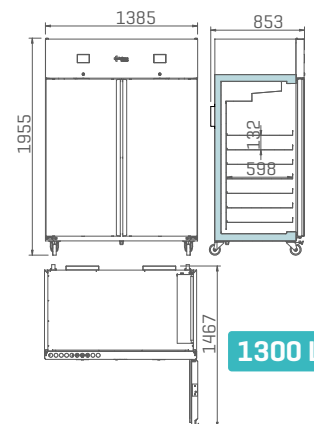

1300 L

PHARMA

1

HEALTH

2

LAB

3

4

5

6

7

8



ULTRA BAJA TEMPERATURA -20° -40° / ULTRA LOW TEMPERATURE -20° -40°



* Pruebas realizadas con una temperatura ambiente de +25°C
* Measured at +25°C ambient temperature and

GAMA SERIES	Lab CARE	Lab CARE PLUS	Lab CARE PLUS
MODELO MODEL	LEUF60S (Static)	LTUF25S	LTUF40S
Rango T° Temperature range [°C]	-20 / -40	-20 / -40	-20 / -40
Capacidad Nominal (litros) Nominal Capacity [litres]	600	250	400
Medidas Exterior (mm) L x P x A Exterior dimensions (mm) W x D x H	750 x 772 x 1966	670 x 720 x 1538	670 x 720 x 1963
Medidas Interior (mm) L x P x1045 A Interior dimensions (mm) W x D x H	624 x 589 x 1594	520 x 484 x 913	520 x 484 x 1337
Claro de puerta (mm) L x A Door opening (mm) W x H	624 x 1557	568 x 855	568 x 1280
Espesor Aislamiento (mm) Insulation thickness (mm)	60	50	50
Acabado Exterior Exterior finishing	Acero Inoxidable Stainless steel	Acero galvanizado plastificado blanco White plastic coated galvanised steel	
Acabado Interior Interior finishing	Acero Inoxidable Stainless steel	Acero galvanizado plastificado blanco White plastic coated galvanised steel	
N° Estantes/Contenedores Shelves/Containers Number	6 / 13	4 Cajones / Drawers	7 Cajones / Drawers
Dimensiones Estantes (mm) L x P Shelf Size (mm) W x D	480 x 618	452 x 423	452 x 423
Material Estantes Shelves Material	Parrilla de alambre cromado Chrome-plated wire shelf	Acero galvanizado con pintura epoxi Epoxy coated galvanised steel	
Intercambiabilidad de Estantes/Cajones Interchangeable Shelves/Drawers	No	Si Yes	
Tipo de Puerta Door Type	Ciega Solid		
Cerradura Lock	Si Yes		
Salida USB USB Port	No	Si Yes	
Datalogger Datalogger	Opcional Optional	Si Yes	
Batería Battery	Opcional Optional	Si Yes	
Sonda simulación producto Product temperature simulation probe	No		
Sonda de temperatura ambiente Interior room temperature probe	Opcional Optional	Si Yes	
Tipo de Controlador Controller type	Digital	Digital Plus	
Tipo de Refrigerante Refrigerant type	R290		
Potencia Eléctrica (W) Electric power (W)	436	572	576
Tensión/Frecuencia (V / Hz) Voltage/Frequency (V / Hz)	230 / 50		
Peso (kg) Weight (kg)	130	132	159

Nos reservamos el derecho a modificar las especificaciones técnicas y constructivas sin previo aviso.
We reserve the right to modify technical and construction specifications without prior notice.



LEUF60S

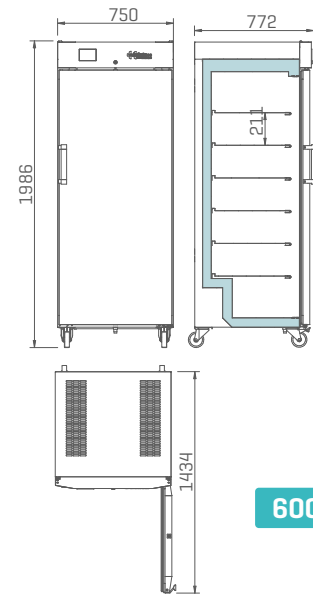
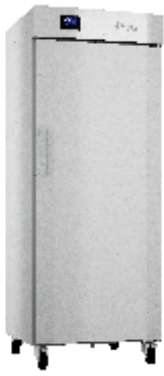

PHARMA

1

HEALTH

2



LTUF25S

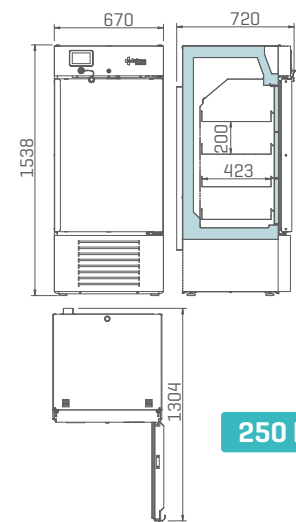

LAB

3

4



LTUF40S

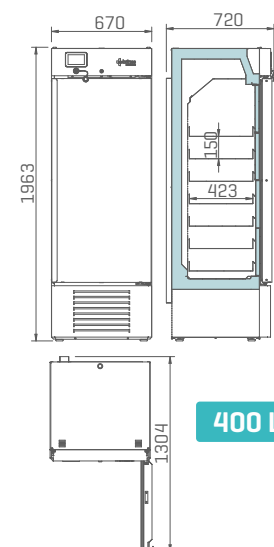

5

6

7

8



ULTRA BAJA TEMPERATURA -20° -40° / ULTRA LOW TEMPERATURE -20° -40°



* Pruebas realizadas con una temperatura ambiente de +25°C
* Measured at +25°C ambient temperature and

GAMA SERIES	Lab CARE PLUS	Lab CARE PLUS	Lab CARE PLUS	Lab CARE PLUS
MODELO MODEL	LTUF65S	LTUF80S	ULF50040	ULF70040
Rango T° Temperature range [°C]	-20 / -40	-20 / -40	-20 / -40	-20 / -40
Capacidad Nominal [litros] Nominal Capacity [litres]	650	800	500	700
Medidas Exterior [mm] L x P x A Exterior dimensions [mm] W x D x H	687 x 855 x 1955	757 x 1037 x 1955	996 x 975 x 1997	1276 x 975 x 1997
Medidas Interior [mm] L x P x A Interior dimensions [mm] W x D x H	534 x 600 x 1207	645 x 768 x 1388	640 x 615 x 1167	920 x 578 x 1165
Claro de puerta [mm] L x A Door opening [mm] W x H	534 x 1350	645 x 1350	667 x 1297	946 x 1297
Espesor Aislamiento [mm] Insulation thickness [mm]	75		120	
Acabado Exterior Exterior finishing	Acero galvanizado plastificado blanco White plastic coated galvanised steel			
Acabado Interior Interior finishing	Acero Inoxidable Stainless steel			
N° Estantes/Cajones Shelves/Drawers Number	7	7	3	3
Dimensiones Estante/Cajón [mm] L x P Shelf/Drawer Size [mm] W x D	412 x 570	524 x 735	617 x 547	897 x 553
Material Estantes/Cajones Shelves/Drawers Material	Acero Inoxidable Stainless steel			
Intercambiabilidad de Estantes/Cajones Interchangeable Shelves/Drawers	Si Yes			
Tipo de Puerta Door Type	Ciega Solid			
Cerradura Lock	Si Yes			
Salida USB USB Port	Si Yes			
Datalogger Datalogger	Si Yes			
Batería Battery	Si Yes			
Sonda simulación producto Product temperature simulation probe	No			
Sonda de temperatura ambiente Interior room temperature probe	Si Yes			
Tipo de Controlador Controller type	Digital Plus			
Tipo de Refrigerante Refrigerant type	R290			
Potencia Eléctrica (W) Electric power [W]	745	745	1062	1098
Tensión/Frecuencia [V / Hz] Voltage/Frequency [V / Hz]	230 / 50			
Peso [kg] Weight [kg]	147	180	265	308

Nos reservamos el derecho a modificar las especificaciones técnicas y constructivas sin previo aviso.
We reserve the right to modify technical and construction specifications without prior notice.



LTUF65S

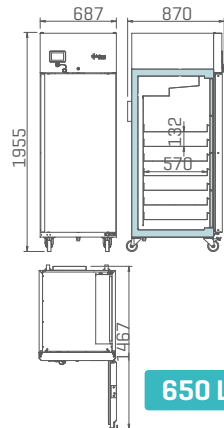

650 L



LTUF80S

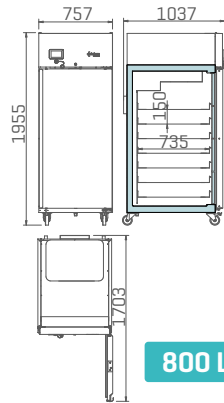

800 L



ULF50040

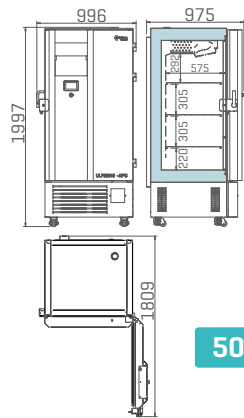

500 L



ULF70040

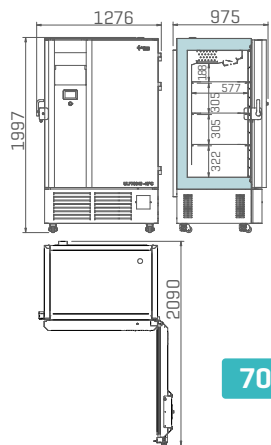

700 L

PHARMA

1

HEALTH

2

LAB

3

4

5

6

7

8

BENEFICIOS DEL ALMACENAMIENTO DURADERO

LONG-TERM STORAGE BENEFITS

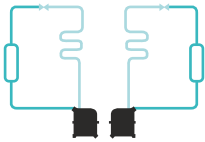

SISTEMA DE DOBLE CIRCUITO FRIGORÍFICO

Sistema de doble circuito frigorífico con compresor con bajo nivel de ruido. En caso de avería de uno, el otro es capaz de mantener la temperatura interior a -70°C.

DOUBLE CIRCUIT COOLING SYSTEM

Double circuit cooling system, with independent and low-noise compressors. In case of failure of one of them, another is able to maintain the internal temperature at -70°C.

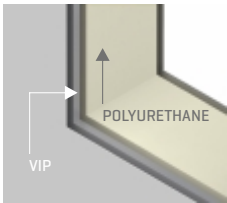

PANELES VIP

Máximo aislamiento y reducción de consumo energético con óptimo aprovechamiento del espacio útil.

VIP INSULATION PANELS

Maximum insulation and reduced energy consumption with optimum space usage.



SISTEMA DE CIERRE ERGONÓMICO

Fácil uso con una sola mano. Cerradura integrada.

ERGONOMIC CLOSING SYSTEM

Single-hand operation. Key lock integrated.



4 NIVELES DE ALMACENAMIENTO [Opcional 5 niveles]

Más de 50.000 microtubos pueden estar almacenados en nuestros racks y cajas estándar.

4 STORAGE LEVELS [5 Levels Optional]

More than 50,000 microtubes may be stored in our standard racks and boxes.



3 PASAMUROS

Posibilidad de introducción de sondas o tubos.

3 ACCESS PORTS

Possibility of introducing probes or tubes.



CAMBIO DE FILTRO SIN HERRAMIENTAS

Filtro lavable y fácil de extraer.

FILTER CHANGE WITHOUT TOOLS

Washable filter and easy to remove.



ACABADO INTERIOR EN ACERO INOXIDABLE
El recubrimiento interior, los estantes y las puertas interiores están fabricadas en acero inoxidable.

INTERIOR STAINLESS STEEL FINISH
Interior coating, shelves and inner doors in stainless steel.



**PORTA-DOCUMENTOS
FRONTAL**

**FRONT DOCUMENT
HOLDER**



CONTROL DIGITAL PLUS
Pantalla digital táctil - alta precisión en el control de temperatura. Datalogger y USB integrados facilitan una rápida recogida de datos.

DIGITAL PLUS CONTROLLER
Graphic touchscreen - high accuracy in temperature control. Built-in Datalogger and USB connection provide quick data transfer.



CÓDIGO DE ACCESO
Sistema de control protegido por contraseña numérica.

ACCESS CODE
Password protected control system.



**GASES REFRIGERANTES
NATURALES HC**
Libre de CFC y HCFC, biodegradable.

**NATURAL HC COOLING
GAS**
CFC's and HCFC's free, biodegradable.



**4 RUEDAS CON PATAS
REGULABLES EN
ALTURA**
Gran estabilidad y fácil reposicionamiento.

**4 CASTERS WITH
HEIGHT ADJUSTABLE
FEET**
Great stability and easy repositioning.

**FÁCIL INTEGRACIÓN CON
UN SISTEMA DE ALARMAS
EXTERNAS**
Contacto libre de potencial y puerto de comunicación Modbus RS485.

**EASY INTEGRATION WITH
AN EXTERNAL ALARM
SYSTEM**
Potential free contact alarm and Modbus RS485 interface port.

PHARMA

1

HEALTH

2

LAB

3

4

5

6

7

8

ULTRA BAJA TEMPERATURA -86° C / ULTRA LOW TEMPERATURE - 86° C

CARACTERÍSTICAS

Con la seguridad como objetivo principal, nuestra gama de congeladores de ultra baja temperatura pretende satisfacer las necesidades más exigentes asegurando un almacenamiento duradero y fiable de las muestras más sensibles.

Esta gama de congeladores está compuesta de diferentes modelos con volúmenes que van desde los 110 a los 800 litros en rangos de temperatura de -40°C a -86°C.

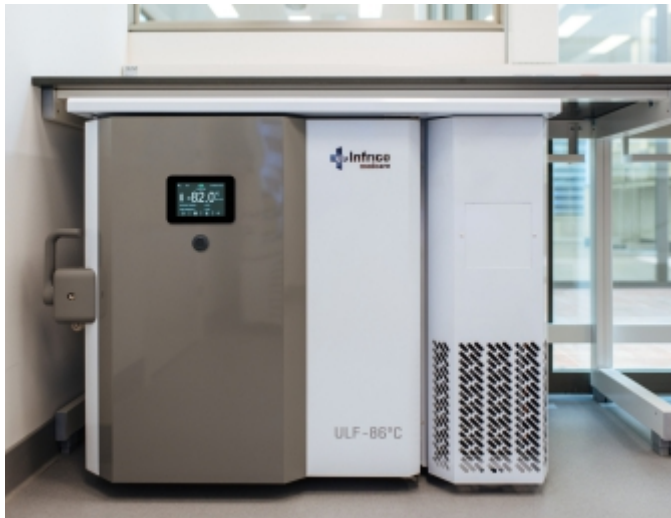

EQUIPAMIENTO

- Rango de temperatura: -40°C / -86°C.
- Capacidad desde 110 a 800 litros con hasta 4 niveles de almacenamiento para más de 50000 microtubos
- Controlador Digital Plus con pantalla TFT táctil de 5 pulgadas fácil e intuitiva [opcional 7 pulgadas]
- Refrigerantes naturales y biodegradables, libres de CFC y HCFC respetuosos con el medio ambiente
- Batería para mantener el registro de temperatura y alarmas hasta 48 horas en caso de fallo de alimentación
- Salida USB integrada en el controlador para una fácil y rápida descarga de datos
- Puertas interiores, estantes y recubrimiento interior fabricado en acero inoxidable
- Sistema de doble circuito frigorífico [excepto ULF11086]
- Máximo aislamiento y reducción de consumo energético con óptimo aprovechamiento del espacio útil
- Cierre ergonómico de gran robustez y fiabilidad
- Apertura de 180° de puerta
- Registro y alta precisión en el control de temperaturas y alarmas

FEATURES

Safety as the main objective, our range of ultra-low temperature freezers aims to satisfy the most demanding needs, ensuring long-term and reliable storage of the most sensitive samples.

This range of freezers is composed of different models with volumes ranges from 110 to 800 litres in temperature ranges from -40 °C to -86 °C.



EQUIPMENT

- Temperature range: -40°C / -86°C.
- Capacity: 110 - 800 litres with up 4 storage levels for more than 50000 microtubes
- Digital Controller 5-inches TFT touch screen, easy and intuitive (7 inches optional)
- Natural HC cooling gas environmentally friendly, CFC's and HCFC's free and biodegradable
- Battery for maintenance the temperature and alarms register in case of power failure for 48 hours
- USB port integrated for easy and quick data transfer
- Interior shelves and inner doors in stainless Steel
- Double circuit cooling system [except ULF11086]
- Maximum insulation and reduced energy consumption with optimum space usage
- Ergonomic, robust and reliable closing system
- Door open 180°
- High accuracy in temperature control



ULTRACONGELADORES ULF MEDCARE

MEDCARE ULF ULTRAFREEZERS



Circuito 1
Circuit 1
Circuito 2
Circuit 2

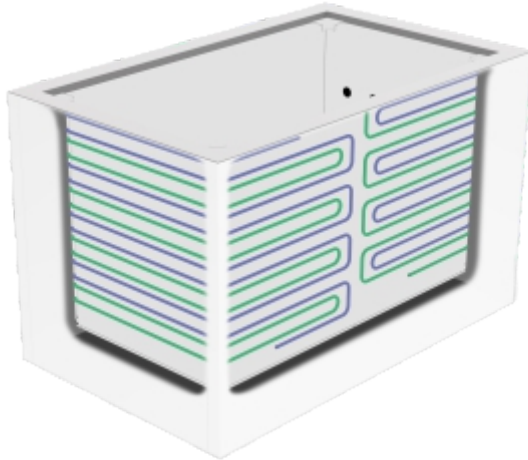

La gama de ultra congeladores MEDCARE ofrece un alto rendimiento y fiabilidad en sus equipos gracias al sistema de doble circuito frigorífico independiente alrededor de la cámara interior.

MEDCARE ultra low freezer range offers high performance and reliability in its equipment thanks to the independent double-circuit refrigeration system around the inner chamber.

CONGELADORES TRADICIONALES

El funcionamiento del ultra congelador depende de un solo compresor. En caso de fallo de este, la temperatura del equipo desciende bruscamente hasta la temperatura ambiente.

TRADITIONAL FREEZERS

Ultra-freezers performance depends on only one compressor. In case of failure of this, temperature rises sharply to room temperature.

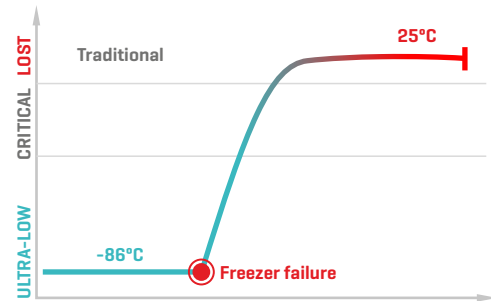
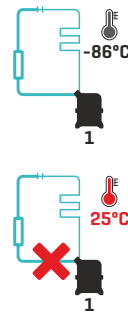

ULTRACONGELADORES ULF MEDCARE

Sistema de doble circuito frigorífico independiente con compresor con bajo nivel de ruido. En caso de fallo de uno de ellos, el otro es capaz de mantener la temperatura del equipo a -70°C.

MEDCARE ULF ULTRAFREEZERS

Double circuit cooling system, with independent and low-noise compressors. In case of failure of one of them, another is able to maintain the internal temperature at -70°C.

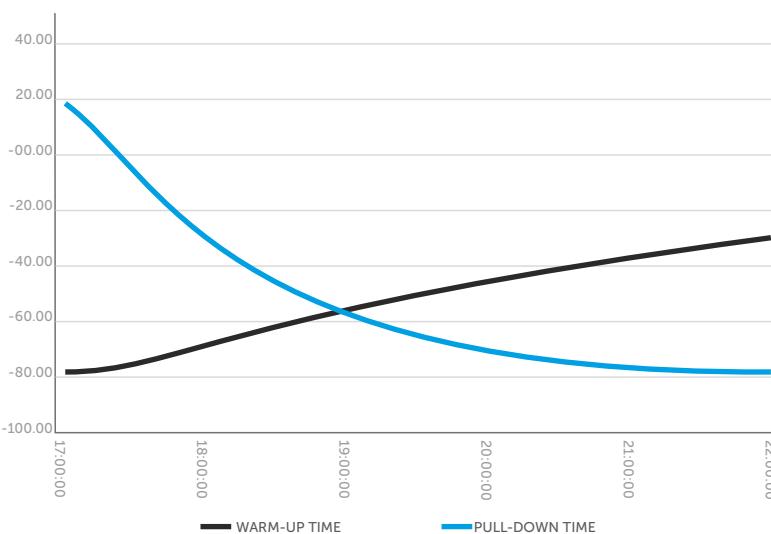
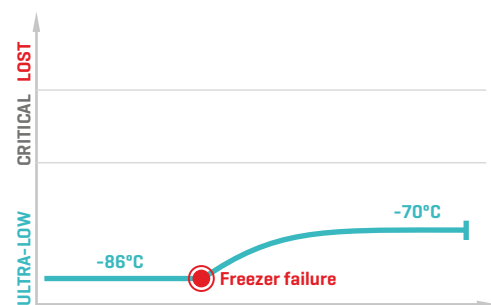
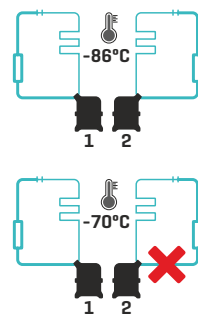

* Pruebas realizadas con una temperatura ambiente de +25°C y 60% Humedad
* Measured at +25°C ambient temperature and 60% Humidity

RENDIMIENTO Y RECUPERACIÓN

Nuestros equipos están equipados con compresores fiables de gran potencia, capaces de dar una rápida respuesta tras aperturas de puerta.

Para mayor seguridad de las muestras, los ultra congeladores pueden dotarse de sistemas de respaldo de CO2.

PERFORMANCE & RECOVERY

Ultra freezers is equipped with reliable high-power compressors, having short recovery times after door openings.

For even higher sample safety, the ultra low freezers can be equipped with CO2 back-up systems.



ULTRA BAJA TEMPERATURA -40° -86° / ULTRA LOW TEMPERATURE -40° -86°

VIP



* Pruebas realizadas con una temperatura ambiente de +25°C
* Measured at +25°C ambient temperature and

GAMA SERIES	Lab CARE PLUS	Lab CARE PLUS	Lab CARE PLUS
MODELO MODEL	ULF11086	ULF40086	ULF50086
Rango T° Temperature range [°C]	-40 / -86	-40 / -86	-40 / -86
Capacidad Nominal [litros] Nominal Capacity [litres]	110	400	500
Medidas Exterior [mm] L x P x A Exterior dimensions [mm] W x D x H	1092 x 827 x 827	846 x 975 x 1997	996 x 975 x 1997
Medidas Interior [mm] L x P x A Interior dimensions [mm] W x D x H	490 x 481 x 530	490 x 619 x 1300	640 x 619 x 1300
Claro de puerta [mm] L x A Door opening [mm] W x H	517 x 527	516 x 1297	666 x 1297
Espesor Aislamiento [mm] Insulation thickness [mm]	120	120 + VIP	
Acabado Exterior Exterior finishing	Acero galvanizado plastificado blanco White plastic coated galvanised steel		
Acabado Interior Interior finishing	Acero Inoxidable Stainless steel		
N° Estantes Shelves Number	1	3	
N° Niveles Levels Number	2	4	
Dimensiones Estante [mm] L x P Shelf Size [mm] W x D	474 x 470	467 x 597	617 x 598
Material Estantes Shelves Material	Acero Inoxidable Stainless steel		
N° de Racks Racks Number	6	12	16
Tipo de Puerta Door Type	Ciega Solid		
Cerradura Lock	Si Yes		
Salida USB USB Port	Si Yes		
Datalogger Datalogger	Si Yes		
Batería Battery	Si Yes		
Sonda simulación producto Product temperature simulation probe	No		
Sonda de temperatura ambiente Interior room temperature probe	Si Yes		
Tipo de Controlador Controller type	Digital Plus		
Tipo de Refrigerante Refrigerant type	HC		
Potencia Eléctrica [W] Electric power [W]	636	1896	1965
Tensión/Frecuencia [V / Hz] Voltage/Frequency [V / Hz]	230 / 50		
Peso [kg] Weight [kg]	110	244	253

Nos reservamos el derecho a modificar las especificaciones técnicas y constructivas sin previo aviso.

We reserve the right to modify technical and construction specifications without prior notice.



ULF11086

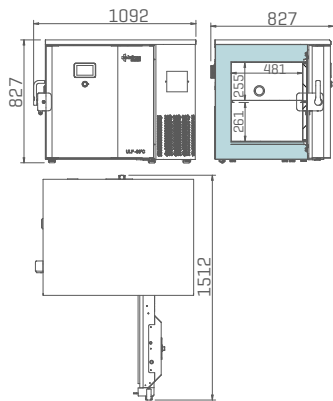
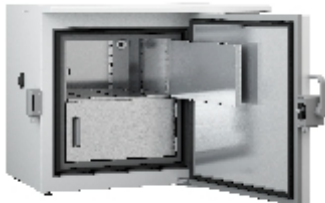

110 L



ULF40086

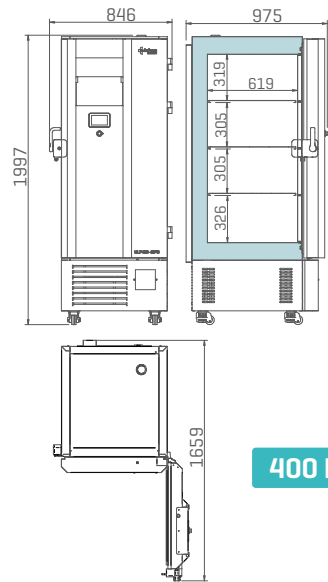

400 L



ULF50086

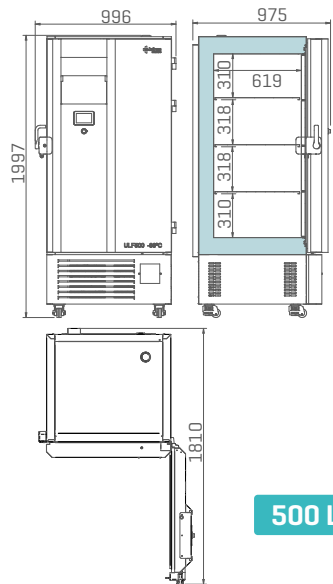

500 L

PHARMA
1
HEALTH
2
LAB
3
4
5
6
7
8



ULTRA BAJA TEMPERATURA -40° -86° / ULTRA LOW TEMPERATURE -40° -86°

VIP



* Pruebas realizadas con una temperatura ambiente de +25°C
* Measured at +25°C ambient temperature and

GAMA SERIES	Lab CARE PLUS	Lab CARE PLUS
MODELO MODEL	ULF70086	ULF80086
Rango T° Temperature range [°C]	-40 / -86	-40 / -86
Capacidad Nominal (litros) Nominal Capacity [litres]	700	800
Medidas Exterior (mm) L x P x A Exterior dimensions [mm] W x D x H	1276 x 975 x 1997	1380 x 975 x 1997
Medidas Interior (mm) L x P x A Interior dimensions [mm] W x D x H	920 x 619 x 1300	1020 x 619 x 1300
Claro de puerta (mm) L x A Door opening [mm] W x H	946 x 1297	1046 x 1297
Espesor Aislamiento (mm) Insulation thickness [mm]	120 + VIP	
Acabado Exterior Exterior finishing	Acero galvanizado plastificado blanco White plastic coated galvanised steel	
Acabado Interior Interior finishing	Acero Inoxidable Stainless steel	
N° Estantes Shelves Number	3	
N° Niveles Levels Number	4	
Dimensiones Estante (mm) L x P Shelf Size [mm] W x D	897 x 598	998 x 598
Material Estantes Shelves Material	Acero Inoxidable Stainless steel	
N° de Racks Racks Number	24	28
Tipo de Puerta Door Type	Ciega Solid	
Cerradura Lock	Si Yes	
Salida USB USB Port	Si Yes	
Datalogger Datalogger	Si Yes	
Batería Battery	Si Yes	
Sonda simulación producto Product temperature simulation probe	No	
Sonda de temperatura ambiente Interior room temperature probe	Si Yes	
Tipo de Controlador Controller type	Digital Plus	
Tipo de Refrigerante Refrigerant type	HC	
Potencia Eléctrica [W] Electric power [W]	2789	2789
Tensión/Frecuencia [V / Hz] Voltage/Frequency [V / Hz]	230 / 50	
Peso [kg] Weight [kg]	311	322

Nos reservamos el derecho a modificar las especificaciones técnicas y constructivas sin previo aviso.

We reserve the right to modify technical and construction specifications without prior notice.



ULF70086

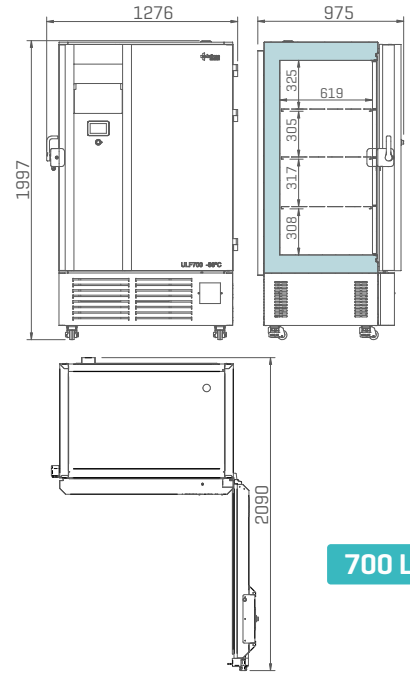

700 L



ULF80086

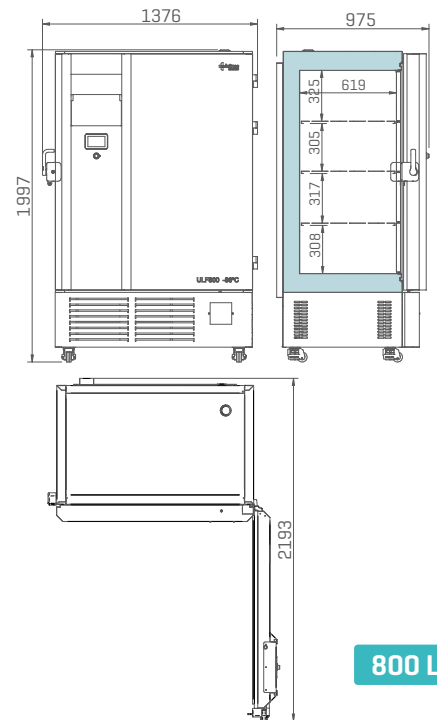

800 L

PHARMA
1
HEALTH
2
LAB
3
4
5
6
7
8



ULTRA BAJA TEMPERATURA -40° -86° / ULTRA LOW TEMPERATURE -40° -86°



* Pruebas realizadas con una temperatura ambiente de +25°C
* Measured at +25°C ambient temperature and

GAMA SERIES	Lab CARE PLUS	
MODELO MODEL	CLF50086	CLF70086
Rango T° Temperature range [°C]	-40 / -86	
Capacidad Nominal (litros) Nominal Capacity [litres]	500	700
Medidas Exterior [mm] L x P x A Exterior dimensions [mm] W x D x H	2011 x 954 x 1092	2291 x 954 x 1092
Medidas Interior [mm] L x P x A Interior dimensions [mm] W x D x H	1190 x 640 x 756	1470 x 640 x 756
Claro de puerta [mm] L x A Door opening [mm] W x H	1190 x 640	1470 x 640
Espesor Aislamiento [mm] Insulation thickness [mm]	120	
Acabado Exterior Exterior finishing	Acero galvanizado plastificado blanco White plastic coated galvanised steel	
Acabado Interior Interior finishing	Acero Inoxidable Stainless steel	
Número Racks Racks number	32	40
Tipo de Puerta Door Type	Ciega Solid	
Cerradura Lock	Si Yes	
Salida USB USB Port	Si Yes	
Datalogger Datalogger	Si Yes	
Batería Battery	Si Yes	
Sonda simulación producto Product temperature simulation probe	No	
Sonda de temperatura ambiente Interior room temperature probe	Si Yes	
Tipo de Controlador Controller type	Digital Plus	
Tipo de Refrigerante Refrigerant type	HC	
Potencia Eléctrica [W] Electric power [W]	1965	2789
Tensión/Frecuencia [V / Hz] Voltage/Frequency [V / Hz]	230 / 50	
Peso [kg] Weight [kg]	253	311

Nos reservamos el derecho a modificar las especificaciones técnicas y constructivas sin previo aviso.

We reserve the right to modify technical and construction specifications without prior notice.



CLF50086

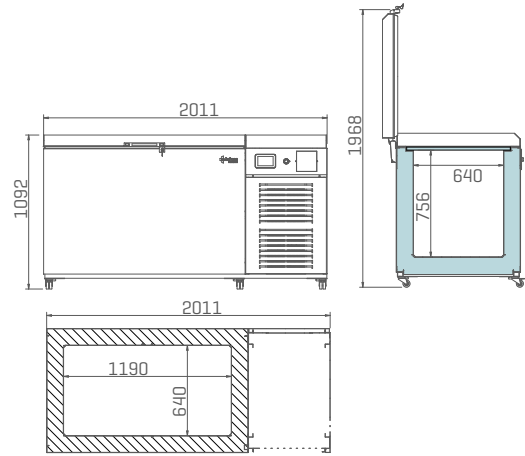

500 L



CLF70086

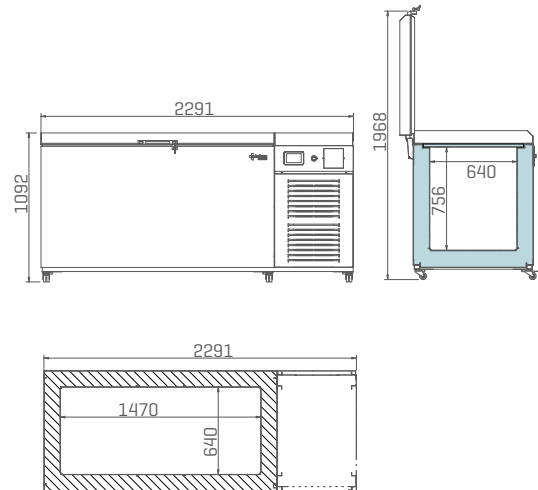

700 L

PHARMA

1

HEALTH

2

LAB

3

4

5

6

7

8



EQUIPAMIENTO OPCIONAL / OPTIONAL EQUIPMENT

Serie ULF



RACK DE ACCESO LATERAL
SIDE ACCES RACK



RACK DESLIZANTE
SLIDING RACK



5 PUERTAS INTERIORES
5 INNER DOORS

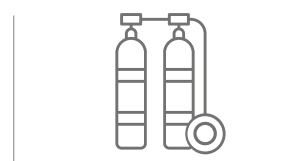

CO₂ BACKUP



GUANTES CRIOGÉNICOS
CRIOGENIC GLOVES



CAPACIDAD DE ALMACENAMIENTO / STORAGE CAPACITY

	ULF11086	ULF40086	ULF50086	ULF70086	ULF80086	CLF50086	CLF70086
Nº Racks Racks Number	6	12	16	24	28	32	40
Nº Caja de 50 mm / 2". 50 mm / 2" Boxes Number	72	252	336	504	588	416	520
Nº Muestras [2ml] caja 50mm. 100/caja Sample vials 2ML [2"BOX]. 100 cell dividers	7200	25200	33600	50400	58800	41600	52000
Nº Caja de 75 mm / 3". 75 mm / 3" Boxes Number	54	180	240	360	420	288	360
Nº Muestras [2ml] caja 75mm. 81/caja Sample vials 2ML [3"BOX]. 81 cell dividers	4374	14580	19440	29160	34020	23328	29160
Nº Caja de 100 mm / 4". 100 mm / 4" Boxes Number	36	120	160	240	280	160	200
Nº Muestras caja 100mm. 81/caja Sample vials 2ML [4"BOX]. 81 cell dividers	2916	9720	12960	19440	22680	12960	16200



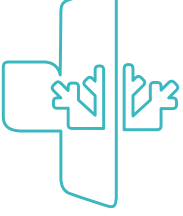

EQUIPAMIENTO OPCIONAL OPTIONAL EQUIPMENT

PHARMA

1

HEALTH

2

LAB

3

4

5

6

7

8



CAMBIO DE CONTROLADOR DIGITAL PLUS A DIGITAL
Modelos acabados en "D", como por ejemplo
LTR70S se convertiría en LTR70SD

CHANGE OF DIGITAL PLUS CONTROLLER TO DIGITAL
Models finished with "D", such as LTR70S will be
converted to LTR70SD.



RUEDAS / PATAS REGULABLES / REGULADORES
DE ALTURA

CASTERS / ADJUSTABLE LEGS / HEIGHT
REGULATORS



EXTERIOR E INTERIOR EN ACERO INOXIDABLE
AISI304

STAINLESS STEEL AISI304 EXTERIOR AND
INTERIOR



PASAMUROS
ACCESS PORT



ESTANTES, CAJONES O COMBINACIÓN DE
AMBOS

SHELVES, DRAWERS OR COMBINED



SEPARADORES DE CAJONES
DRAWERS DIVISORS



SONDA DE SIMULACIÓN DE PRODUCTO
PRODUCT SIMULATION TEMPERATURE PROBE

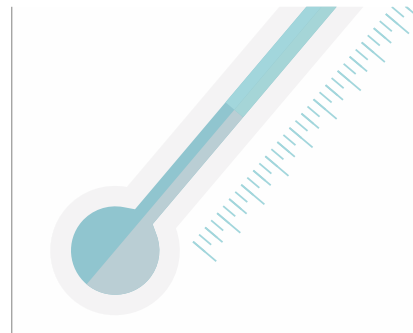

SONDA DE TEMPERATURA AMBIENTE
INTERIOR ROOM TEMPERATURE PROBE



REGISTRADOR CIRCULAR DE PLUMILLA
TEMPERATURE CHART RECORDER



EQUIPAMIENTO OPCIONAL / OPTIONAL EQUIPMENT



TERMOSTATO DIGITAL ANTICONGELACIÓN
FREEZING PROTECTION ELECTRONIC CONTROLLER



DESESCARCHE POR GAS CALIENTE
HOT GAS DEFROST



CLASE CLIMÁTICA 5 +40° C / 40%
CLIMATE CLASS 5 + 40° C / 40%



BATERÍA
BATTERY



CONEXIÓN ELÉCTRICA - DIFERENTES TI
ELECTRICAL CONNECTION - DIFFERENT
220V/60Hz; 115V/60Hz



TOMA DE CORRIENTE INTERNA
INTERNAL PLUG

MÚLTIPLES CLAVIJAS

SPECIAL PLUGS



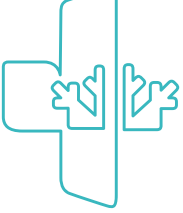

EQUIPAMIENTO OPCIONAL / OPTIONAL EQUIPMENT

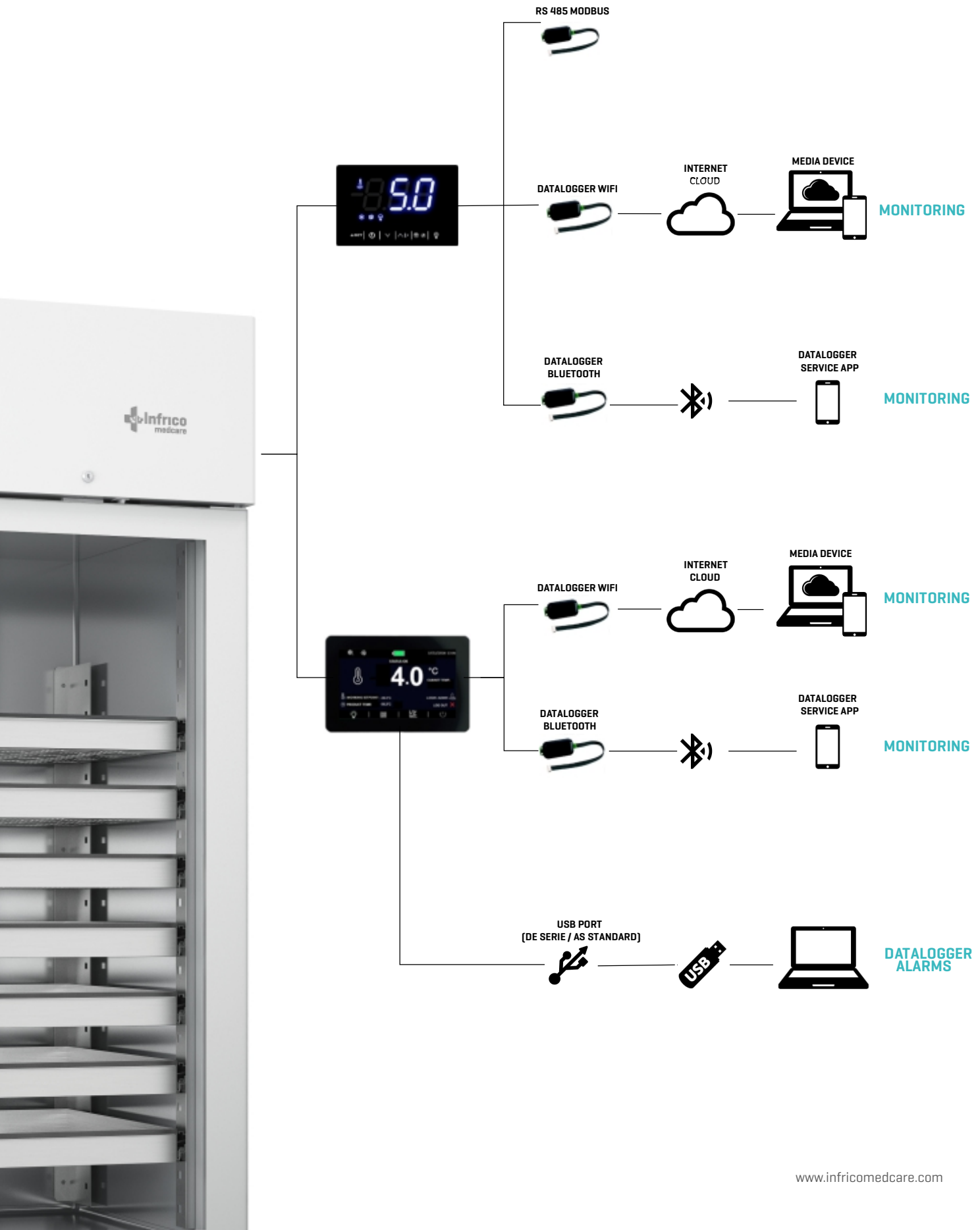



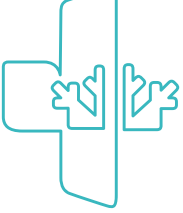

EQUIPAMIENTO COMPLEMENTARIO

COMPLEMENTARY EQUIPMENT

Para poder satisfacer las necesidades de todo tipo de laboratorios e instalaciones sanitarias, Infrico Medcare completa su ya amplia gama de refrigeración y congelación con varios equipos complementarios que son de gran uso en este sector. En esta sección ofrecemos a nuestros clientes equipos como cámaras frigoríficas modulares y estanterías, arcones congeladores, máquinas de hielo o de lavado.

In order to satisfy the needs of all types of laboratories and sanitary facilities, Infrico Medcare completes its already wide range of refrigerators and freezers by several complementary equipments that are of great use in this sector. In this section, we offer our customers products such as modular cold rooms and shelves, chest freezers, ice makers or washing machines.



CÁMARAS FRIGORÍFICAS MODULARES **MODULAR COLD-ROOMS**



ESTANTERÍAS MODULARES **MODULAR SHELVING SYSTEM**



ARCONES CONGELADORES **CHEST FREEZERS**



MÁQUINAS DE HIELO TROCEADO **CRUSHED ICE MAKERS**



MÁQUINAS DE LAVADO **WASHING MACHINES**



SOLUCIONES A MEDIDA **CUSTOMISED SOLUTIONS**

PHARMA

1

HEALTH

2

LAB

3

4

5

6

7

8



GAMA POLAR MAX / POLAR MAX SERIES



Puerta
corredera
opcional

Optional
sliding
door

Panel Panel	Revestimiento Coating	Chapa de acero galvanizado y prelacado poliéster con un film de protección, color blanco RAL 9010 y calidad alimentaria Standard coating of galvanised metal plate painted with white food-certified paint, colour RAL 9010 and protective film
Panel suelo Floor panel	Suelo standard Standard Floor	Cara interior en madera fenólica de 9 mm antideslizante Non-skid 9 mm phenolic plywood interior Cara exterior chapa de acero galvanizado prelacado con poliéster White painted galvanised steel exterior
Espesor Thickness	Aislamiento Insulation	80mm [T ⁺] 100mm [T ⁻] Espuma de poliuretano libre de CFC's inyectado a alta presión con densidad de 45 kg/m ³ CFC's-free polyurethane injected at high pressure with density of 43-45 kg/m ³
Dimensiones interiores Interior dimensions	Largo y fondo Width and depth	120 x 120 cm a 440 x 240 cm [módulos de 20 cm] 120 x 120 cm to 440 x 240 cm [modules of 20 cm]
	Altura Height	192 cm - 212 cm - 232 cm - 252 cm - 272 cm
Dimensiones exteriores Exterior dimensions	Largo y fondo Width and depth	Dimensiones interiores + 16 cm [e=80] + 20cm [e=100] Interior dimensions + 16 cm [e=80] + 20cm [e=100]
	Altura con suelo Height with floor	Dimensiones interiores + 16 cm [e=80] + 20cm [e=100] Interior dimensions + 16 cm [e=80] + 20cm [e=100]
	Altura sin suelo Height without floor	Dimensiones interiores + 8 cm [e=80] + 10cm [e=100] Interior dimensions + 8 cm [e=80] + 10cm [e=100]
Puerta Door	Puerta pivotante estándar con luz libre 1830x800 mm, cierre con llave y sistema de apertura interior Pivot hinge door with standard dimensions for door opening of 1830x800 mm, interior opening system and key lock	

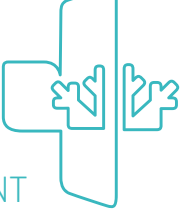

EQUIPAMIENTO COMPLEMENTARIO / COMPLEMENTARY EQUIPMENT

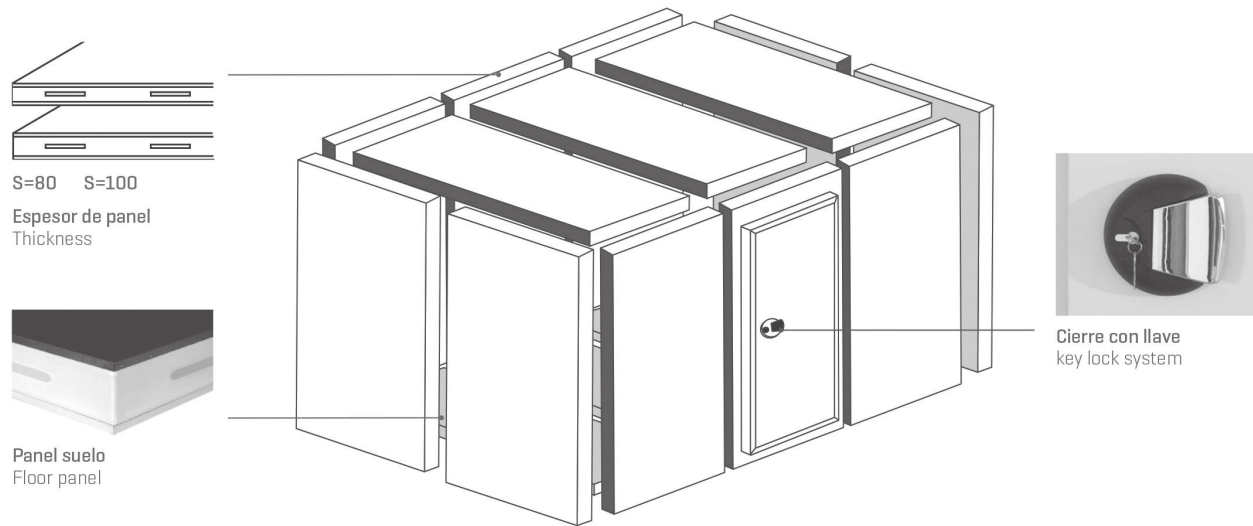

PHARMA

1

HEALTH

2

LAB

3

4

5

6

7

8

Modularidad cada 200 mm **Modularity every 200 mm**

Para cualquier otra medida de largo, fondo o altura exterior de una cámara frigorífica Polar Max o Multirecinto de Cámaras, rogamos consulten nuestro departamento técnico comercial.

For any other width, depth or height measurement of our Polar Max cold-room, please contact our technical / sales department.



Bisagras regulables en altura y profundidad Height and depth adjustable hinges

Contrapuerta embutida Inserted inner door

Sistema de apertura interior del cierre Interior opening system

Perfil radio sanitario incorporado en el panel Sanitary rounded profile

Panel modular con perfil machihembrado
Modular panel with tongue and groove profile



Ejemplo modularidad
Modularity example



Innovador sistema de unión "clipart" el cual no incorpora piezas metálicas.
Innovative union system "clip art" which does not incorporate metal parts





GAMA CM / CM SERIES



Puerta
corredera
opcional

Optional
sliding
door

Panel Panel	Revestimiento Coating	Chapa de acero galvanizado y prelacado poliéster con un film de protección, color blanco RAL 9010 y calidad alimentaria Standard coating of galvanised steel painted with white food-certified paint, colour RAL 9010 and protective film
Panel suelo (e= 100 mm) Floor panel (e= 100 mm)	Suelo standard Standard Floor	Cara interior en acero inoxidable AISI 304 espacio antideslizante Innerside in stainless steel AISI 304 interior Cara exterior chapa de acero galvanizado prelacado con poliéster White painted galvanised steel exterior
Espesor Thickness	Aislamiento Insulation	80mm [Tª +] 100mm [Tª -] Espuma de poliuretano libre de CFC' s inyectado a alta presión con densidad de 45 kg/m3 CFC' s-free polyurethane injected at high pressure with a density of 43-45 kg/m3
Dimensiones interiores Interior dimensions	Largo y fondo Width and depth	124 x 124 cm a 444 x 244 cm [módulos de 20 cm] 124 x 124 cm a 444 x 244 cm [modules of 20 cm]
	Altura Height	196 cm - 216 cm - 236 cm - 256 cm - 276 cm
Dimensiones exteriores Exterior dimensions	Largo y fondo Width and depth	Dimensiones interiores + 16 cm [e=80] + 20cm [e=100] Interior dimensions + 16 cm [e=80] + 20cm [e=100]
	Altura con suelo Height with floor	Dimensiones interiores + 16 cm [e=80] + 20cm [e=100] Interior dimensions + 16 cm [e=80] + 20cm [e=100]
	Altura sin suelo Height without floor	Dimensiones interiores + 8 cm [e=80] + 10cm [e=100] Interior dimensions + 8 cm [e=80] + 10cm [e=100]
Sistema ensamble Assembly system	Cajas excéntricas de ABS dotadas de piezas excéntricas de alta resistencia y gancho reforzado Structural profile with high resistance made of ABS plastic and strong hook	
Perfiles Profiles	Tubulares perimetrales de PVC que incorporan el radio sanitario Perimeter tubular profiles made of PVC with sanitary rounded corners	
Puerta Door	Pivotante con herraje de poliamida, aleación de aluminio y anodizado inox. Pivot hinges made of polyamide, aluminium alloy and stainless steel	
Medidas puerta Door dimensions	Claro de puerta grande 1830 x 800 mm Standard dimensions for doors of 1830 x 800 mm	

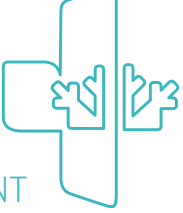

EQUIPAMIENTO COMPLEMENTARIO / COMPLEMENTARY EQUIPMENT

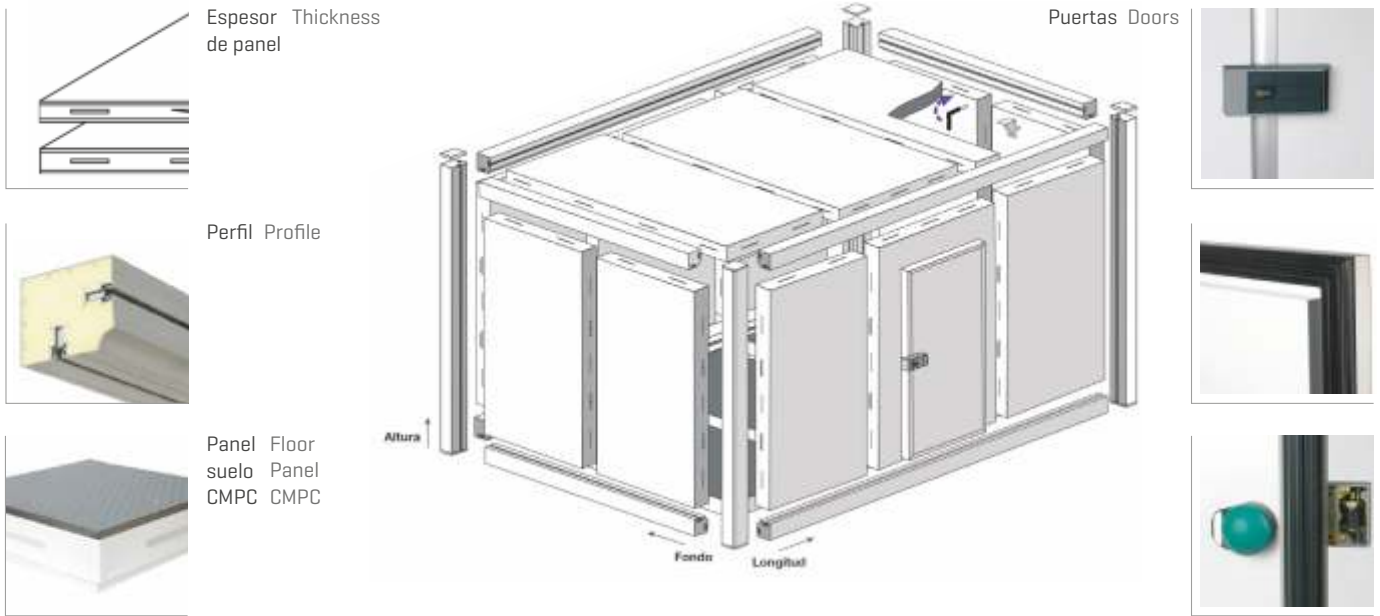

Modularidad cada 200 mm / **Modularity every 200 mm**

Para cualquier otra medida de largo, fondo o altura exterior de una cámara frigorífica Polar Max o Multirecinto de Cámaras, rogamos consulten nuestro departamento técnico comercial.

For any other width, depth or height measurement of our Polar Max cold-room, please contact our technical/sales department.



Cámaras con suelo y sin suelos. División modular interior.

Rooms with floor and without floor. Rooms and interior partitions.

Multirecinto de cámaras adosadas / Multiple adjacent cold-rooms



PHARMA

1

HEALTH

2

LAB

3

4

5

6

7

8



ESTANTERÍAS MODULARES / MODULAR SHELVING

Estas estanterías están diseñadas para satisfacer cualquier necesidad de organización, pensando en las diferentes necesidades de un profesional. Están certificadas en materia de calidad y aptitud para uso alimentario, por lo que su uso se extiende desde hostelería, hasta laboratorios, hospitales, salas limpias o cualquier otro establecimiento que precise de un instrumento de almacenaje de garantías.

CARACTERÍSTICAS TÉCNICAS

- Especialmente diseñadas para uso alimentario
- Fáciles de montar, sin necesidad de herramientas
- Estructura robusta en duraluminio anodizado
- Tornillería en acero inoxidable
- Parrillas autoventiladas, amovibles y lavables en lavavajillas
- Calidad polietileno
- Estantes regulables en altura cada 150 mm
- Composiciones modulares adaptables a todos los espacios
- 3 profundidades: 370, 470 y 560*mm [*proporcional Gastronorm]
- Homologación NF de higiene alimentaria y Certificación ISO 9001
- Especialmente aptas para uso en cámaras frigoríficas tanto con temperaturas positivas [conservación] como negativas [congelación]

This shelving has been designed to suit any professional need. The system is certified for its quality processes and suitability for food use. That is why its use is recommended for many businesses: hotels and restaurants, laboratories, hospitals, clean rooms and any other establishment that requires a storage instrument with guarantees.

TECHNICAL FEATURES

- Specially designed for alimentary use
- Easy to assemble, without tools: Strong structure built in anodised duraluminium
- Stainless steel screws
- Autoventilated, removable and dishwasher safe grids
- Quality polyethylene shelves can be placed every 150mm
- Modular compositions adaptable to any space
- 3 depths: 370, 470 and 560*mm [*Gastronorm proportional]
- NF alimentary hygiene normalization, and ISO 9001
- Specially suitable for its use in cool rooms, both in positive and negative temperatures



Gran capacidad y resistencia	High capacity and endurance
<1m = 120Kg;	<1m = 120Kg;
>1m = 100Kg	>1m = 100Kg



MONTAJE RÁPIDO
No hay necesidad de herramientas, tornillos o mano de obra especializada, nuestro sistema de estanterías permite un montaje rápido y fácil.

EASY ASSEMBLY
No need for tools, screws or skilled labour. Our shelving system allows for a really quick and easy assembly.

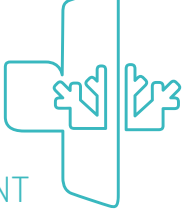

EQUIPAMIENTO COMPLEMENTARIO / COMPLEMENTARY EQUIPMENT

TOTAL MODULARIDAD PARA UN MÁXIMO APROVECHAMIENTO DEL ESPACIO
La eficacia del sistema en la maximización de espacios es posible gracias a su juego de estantes [hasta 10] y a su capacidad de montajes angulares que favorecen una perfecta adaptación a las áreas disponibles.

TOTAL MODULARITY FOR MAXIMUM USE OF SPACE
System's effectiveness in maximizing space is possible thanks to its set of shelves [up to 10] and their ability to angle assembly, favouring a perfect fit.



HIGIENE ALIMENTARIA

MATERIALES RESISTENTES, HIGIÉNICOS Y DE LARGA DURACIÓN
Todos los elementos de soporte están fabricados en aluminio anodizado de 15 micrones, siendo los propios estantes de polietileno de alta resistencia. Están recomendados no sólo para una utilización en condiciones climáticas templadas, sino también para su uso en cámaras frigoríficas. Todos los elementos están testados para resistir temperaturas frías sin perder sus propiedades.

ROBUST, HYGIENIC AND LONG LASTING MATERIALS
All supporting elements are made of anodised aluminium of 15 micron, with high resistance of polyethylene shelves. They are recommended, not only for use in warm weather conditions, but also for use in cold rooms. All items are tested to resist cold temperatures without losing their properties.



UN CONJUNTO EQUILIBRADO
Los pies regulables aseguran que cualquier conjunto de estantería tenga un total equilibrio en caso de que la superficie donde se instala no sea totalmente llana.

A BALANCED SET
The adjustable feet ensure that any set of shelves has a total balance if the surface where it is installed is not completely flat.



EMBALAJE REDUCIDO
Los conjuntos se suministran en un embalaje termosellado y retráctil que posibilita que su almacenamiento ocupe menos espacio posible.

REDUCED PACKAGING
The sets are supplied in heat sealing packaging that enables storage to occupy the least space possible.

SOLICITENOS PRESUPUESTO REQUEST A QUOTE

PHARMA

1

HEALTH

2

LAB

3

4

5

6

7

8



ARCONES CONGELADORES / CHEST FREEZERS

CARACTERÍSTICAS TÉCNICAS

- Exterior en chapa galvanizada y plastificada en blanco
- Cuba interior en aluminio [Mod. AL] o acero inoxidable. [Mod. I]
- Aislamiento en poliuretano inyectado a alta presión [100% libre de CFC's], con 70 mm de espesor, excepto el mod. CH550 con espesor 55 mm y mod. HF 700 con espesor 60 mm
- Termómetro analógico, termostato regulable con la posibilidad de congelación rápida
- Tapa abatible con cerradura y llave
- Luz interior

TECHNICAL FEATURES

- Galvanised steel exterior, white plastic coated
- Aluminium interior [Mod. AL] or stainless steel. [Mod. I]
- High pressure injected polyurethane isolation to [100% free one of CFC's], with 70 mm of thickness, except mod. CH550 with thickness 55 mm and mod. HF 700 with thickness 60 mm
- Analogical thermometer, adjustable thermostat with the possibility of fast freezing
- Lid with integrated lock and key
- Inner light



HF 500 AL

MODELOS / MODELS	HF 240 HC	HF 320 HC	HF 400 HC	HF 500 HC	HF 550 HC	HF 700 HC
Largo Width [mm]	827	990	1165	1400	1596	1570
Fondo Depth [mm]	660	660	660	660	660	750
Alto Height [mm]	860	860	860	860	860	1005
Potencia Power [W]	120	146	167	180	200	261
Tensión Frecuencia [V/Hz]	220-240/50	220-240/50	220-240/50	220-240/50	220-240/50	220-240/50
Capacidad útil Capacity [L]	176	220	285	344	439	664
Nº Cesta [Serie/Opcional] Nº of Baskets [Standard/Optional]	2/0	2/0	2/1	2/3	2/4	2/2
Compresor Compressor [HP]	1/7	1/6	1/5	1/5+	1/4+	1/3
Condensación Condensation	Estática Static	Estática Static	Estática Static	Estática Static	Ventilada Ventilated	Ventilada Ventilated
Evaporación Evaporation	Estática Static	Estática Static	Estática Static	Estática Static	Estática Static	Estática Static
Temperatura Temperature [32°C]	-18°C a -24°C	-18°C a -24°C	-18°C a -24°C	-18°C a -24°C	-18°C a -24°C	-18°C a -24°C
Desescarche Defrost	Manual	Manual	Manual	Manual	Manual	Manual
Refrigerante Refrigerant	R600a	R600a	R600a	R600a	R600a	R600a
Capacidad de congelación Freezing capacity [Kg/24h]	12	16	18	20	24	42

Características técnicas y constructivas sujetas a variación sin previo aviso
We reserve the right to change specifications without prior notice

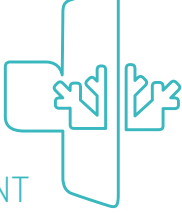

MÁQUINAS DE HIELO TROCEADO / CRUSHED ICE MAKERS

PHARMA
1
HEALTH
2
LAB
3
4
5
6
7
8

CARACTERÍSTICAS TÉCNICAS

- Hielo compacto troceado, de perfecta aplicación en el sector de la industria química y farmacéutica

Serie T:

- Exterior en acero inox AISI 304 y carrocería monoblock en inox con aislamiento en poliuretano inyectado a alta presión libre de CFC's
- Cuba y puerta en ABS alimentario
- Producción en condiciones óptimas: temperatura ambiente 21°C, temperatura agua 15°C
- Entrada agua Ø 3/4 y salida Ø 24 mm
- Gas refrigerante R290
- Tensión / Frecuencia: 220-240V/50 Hz

TECHNICAL FEATURES

- Compact crushed ice, perfectly suitable for the chemical and pharmaceutical sectors

T Series:

- Exterior in AISI 304 stainless steel and monoblock body in stainless steel with CFC's-free, high-pressure injected polyurethane insulation
- Tank and door in ABS food-grade plastic
- Production in optimum conditions: room temperature 21°C, water temperature 15°C. Water inlet Ø 3/4 and outlet Ø 24 mm
- Cooling gas R290
- Voltage / Frequency: 220-240V/50 Hz

FHT 155 A/W HC



MODELOS / MODELS	FHT60A/W HC	FHT90A/W HC	FHT155A/W HC
Largo [mm] / Width [mm]	450	500	738
Fondo [mm] / Depth [mm]	620	660	690
Alto sin patas [mm] / Height [mm]	680	800	1020
Condensación / Condensation	Aire / Agua Air / Water	Aire / Agua Air / Water	Aire / Agua Air / Water
Producción / Production capacity [Kg]	67	113	153
Almacén [Kg] / Storage capacity [Kg]	9	30	55
Potencia [W] / Power [W]	400	470	700





CONTROL ELECTROMECAÁNICO / ELECTROMECHANICAL CONTROL

LV 2535



CARACTERÍSTICAS TÉCNICAS

- Estructura interior y exterior en acero inoxidable
- Puerta construida en doble pared
- Brazos de lavado inferior en acero inoxidable y superior en composite.
- Modelo LVP3040 con lavado superior
- Brazos de aclarado en composite
- Nueva placa electrónica común para toda la gama, con conexión USB para su actualización y programación
- En el Display posibilidad de visionar temperatura de lavado y aclarado, así como códigos de errores
- Programa de auto limpieza ProSelf a realizar al final de la jornada
- Posibilidad de regular a través de la placa los dosificadores de producto químico
- Bombas de lavado con sistema DuoFlo Sistema de bomba con una entrada y dos salidas, de esta forma se elimina la pérdida de potencia y el ruido disminuye, mejora el rendimiento y disminuye el consumo de energía [excepto en el modelo LV2535]
- Dosificador de abrillantador peristáltico con regulación electrónica al igual que el dosificado de detergente [opcional]
- Modelos con Bomba desagüe [BD] con descarga parcial. Durante el aclarado se introduce agua limpia en la cuba para sustituir la sucia, se realizan aportaciones continuas de agua limpia y cuando termina el ciclo de lavado parte del agua de la cuba ha sido renovada. Garantizamos un caudal en litros constantes en el aclarado independientemente de la presión del agua de red
- Opcional:
 - Dosificador detergente [D]
 - Kit Bomba desagüe sin descarga parcial [BD]

TECHNICAL FEATURES

- Interior and exterior made of stainless steel
- Door made of double panel
- Lower wash arms in stainless steel and upper in composite.
- LVP3040 model with superior wash
- Rinsing arms in composite
- New common electronics board for the whole range, with USB connection for updating and programming
- In the Display it is possible to view wash and rinse temperature, as well as error codes
- ProSelf self-cleaning program to be done at the end of the day
- Possibility to regulate through the plate of the chemical product dispenser
- Washing pump with DuoFlo system. Pump system with one inlet and two outlets, which eliminates loss of power and noise decreases, improves performance and decreases energy consumption [except in the LV2535 model]
- Dosing of peristaltic rinse aid with electronic regulation as well as dosage detergent [optional]
- Models with drain pump [BD] with partial discharge. During rinsing clean water is introduced into the tank to replace the dirty water. Continuous contributions of clean water are made, when the washing cycle is finished some of the water in the tank has been renewed. We guarantee a constant flow of litres during the rinsing regardless of the mains water pressure
- Optional:
 - Detergent dosing [D]
 - Kit Drain pump without partial discharge [BD]

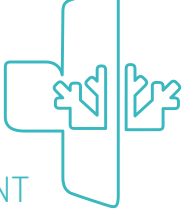

EQUIPAMIENTO COMPLEMENTARIO / COMPLEMENTARY EQUIPMENT



Modelo Model	LV2535	LVP3040	LVP2845	LVP3250
Dimensiones [mm] [LxPxA] Dimensions [mm] [WxDxH]	400x510x595	440x540x670	530x560x710	580x600x830
Medidas de cesta [mm] Baskets measures [mm]	350x350	385x385	450x450	500x500
Altura útil de lavado [mm] Washing useful height [mm]	250	300	280	325
Ciclos de lavado estándar [Seg.] Standard washing cycles [Seg.]	120	120	120	90/150
Producción horaria cestas /h Hourly production baskets /h	30	30	30	40/24
Tensión/Frecuencia [V/Hz] Voltage / Frequency [V/Hz]	230V/50Hz	230V/50Hz	230V/50Hz	230V/50Hz
Potencia máxima funcionamiento [W] Maximum power [W]	3350	3400	3400	3500
Potencia resistencia cuba [W] Tank heater power [W]	600	600	600	2100
Potencia resistencia boiler [W] Boiler heater power [W]	2600	2600	2600	3000
Potencia bomba lavado [W] Pump power [W]	150	200	200	470
Temp. Lavado / Aclarado [°C] Washing / rinsing temp. [°C]	60°C/65°C	60°C/65°C	60°C/65°C	60°C/80°C
Capacidad cuba/boiler [L] Boiler / tank capacity [L]	7/2,6	9/2,6	14/2,6	20/6
Consumo agua ciclo [L] Water cycle consumption [L]	1,8	1,8	1,8	2,2
Dotación Dotation	2 cestos vasos, 1 contenedor cubiertos, 1 insertador platos 2 flat racks, 1 cutlery container, 1 plates rack	1 cesto vasos, 1 Cesto platos, 1 contenedor cubiertos, 1 insertador platos 1 flat rack, 1 plates container, 1 cutlery container, 1 plates rack	1 cesto vasos, 1 Cesto platos, 1 contenedor cubiertos, 1 insertador platos 1 flat rack, 1 plates container, 1 cutlery container, 1 plates rack	1 cesto vasos, 1 Cesto platos, 1 contenedor cubiertos 1 flat rack, 1 plates container, 1 cutlery container

D: Dosificador detergente BD: Bomba desagüe

D: Detergent dispenser BD: Drain pump

PHARMA

1

HEALTH

2

LAB

3

4

5

6

7

8



CONTROL ELECTRÓNICO / ELECTRONIC CONTROL

LVP 3250 E



CARACTERÍSTICAS TÉCNICAS

- Estructura interior y exterior en acero inoxidable
- Puerta construida en doble pared
- Brazos de lavado inferior en acero inoxidable y superior en composite. Modelo LVP3040E con lavado superior
- Brazos de aclarado en composite
- Nueva placa electrónica común para toda la gama, con conexión USB para su actualización y programación
- En el Display posibilidad de visionar temperatura de lavado y aclarado, códigos de errores, así como programas y fases del programa
- Cinco programas de lavado, con posibilidad de modificar tiempos
- Tres programas de tiempos 60, 120 y 150 segundos, lavado continuo y programa de auto limpieza ProSelf a realizar al final de la jornada y descarga automática en los modelos con bomba desagüe [BD] con descarga parcial
- Posibilidad de regular a través de la placa los dosificadores de producto químico
- Bombas de lavado con sistema DuoFlo, sistema de bomba con una entrada y dos salidas, de esta forma se elimina la pérdida de potencia y el ruido disminuye, mejora el rendimiento y disminuye el consumo de energía
- Dosificado de abrillantador peristáltico con regulación electrónica al igual que el dosificado detergente [opcional], modelos con código [D] dosificador de detergente de serie
- Modelos con Bomba desagüe [BD] con descarga parcial
- Opcional:
- Kit Bomba desagüe sin descarga parcial [BD]

TECHNICAL FEATURES

- Interior and exterior made of stainless steel.
- Door made of double panel
- Lower wash arms in stainless steel and upper in composite. LVP3040E model with superior wash
- Rinsing arms in composite
- New common electronics board for the whole range, with USB connection for updating and programming
- In the Display it is possible to view wash and rinse temperature, error codes as well as programs and program phases
- Five washing programs, with possibility to modify cycles
- Three 60, 120 and 150 seconds programs, continuous washing and ProSelf self-cleaning program to be performed at the end of the day and automatic discharge in the models with partial discharge drain [BD]
- Possibility to regulate through the plate of the chemical product dispenser
- Washing pump with DuoFlo system. Pump system with one inlet and two outlets, which prevents power loss and noise decreases, improves performance and decreases energy consumption
- Dosing of peristaltic rinse aid with electronic regulation as well as dosage detergent [optional], models with code [D] - detergent dispenser as standard
- Models with drain pump [BD] with partial discharge
- Optional:
- Kit Drain pump without partial discharge [BD]

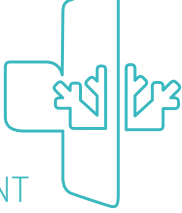

EQUIPAMIENTO COMPLEMENTARIO / COMPLEMENTARY EQUIPMENT



Modelo Model	LVP3040E	LVP3250E
Dimensiones [mm] [LxPxA] Dimensions [mm] [WxDxH]	440 x 540 x 670	580 x 600 x 830
Medidas de cesta [mm] Baskets measures [mm]	385 x 385	500 x 500
Altura útil de lavado [mm] Washing useful height [mm]	300	325
Ciclos de lavado estándar [Seg.] Standard washing cycles [Seg.]	60 / 120 / 150 / Continuo / Autolimpieza 60 / 120 / 150 / Continuos / Self-cleaning	60 / 120 / 150 / Continuo / Autolimpieza 60 / 120 / 150 / Continuos / Self-cleaning
Producción horaria cestas /h Hourly production baskets /h	40 / 30 / 24	40 / 30 / 24
Tensión/Frecuencia [V/Hz] Voltage / Frequency [V/Hz]	230V/50Hz	230V/50Hz
Potencia máxima funcionamiento [W] Maximum power [W]	3400	3500
Potencia resistencia cuba [W] Tank heater power [W]	600	2100
Potencia resistencia boiler [W] Boiler heater power [W]	2600	3000
Potencia bomba lavado [W] Pump power [W]	200	470
Temp. Lavado / Aclarado [°C] Washing / rinsing temp. [°C]	60°C/65°C	60°C/80°C
Capacidad cuba/boiler [L] Boiler / tank capacity [L]	9/2,6	20/6
Consumo agua ciclo [L] Water cycle consumption [L]	1,8	2,2
Dotación Dotation	1 cesto vasos, 1 cesto platos, 1 contenedor cubiertos, 1 insertador platos 1 flat rack, 1 plates container, 1 cutlery container, 1 plates rack	1 cesto vasos, 1 cesto platos, 1 contenedor cubiertos 1 flat rack, 1 plates container, 1 cutlery container

D: Dosificador detergente BD: Bomba desagüe

D: Detergent dispenser BD: Drain pump

PHARMA

1

HEALTH

2

LAB

3

4

5

6

7

8



LAVAUTENSILIOS / UTENSIL WASHERS

LP 6561



CARACTERÍSTICAS TÉCNICAS

- Estructura en doble pared en acero inox, este diseño nos permite reducir la dispersión térmica y acústica.
- Brazos de lavado y aclarado independientes en acero inox, garantizan resultados óptimos de los ciclos de lavado.
- Display con posibilidad de visionar temperatura de lavado y aclarado y códigos de errores.
- Cubas, contrapuestas y guías estampadas con cantos redondeados y dobles filtros en inoxidable.
- Sistema de aclarado UltraRinse [prestación de aclarado constante], nos permite mantener temperatura del agua constante durante la fase de aclarado, así como una presión y caudal del agua del aclarado constante independiente de las condiciones de la red hidráulica.
- Dosificador de abrillantador y detergente peristálticos, con posibilidad de regularlos en el panel de mandos.
- Opcional:
 - Soporte 8 bandejas profundidad máxima 4cm para LP [medidas 50x50cm]
 - Soporte Inox 5 bandejas para LP profundidad máxima 6,5cm [medidas 50x50cm]
 - Contenedor cubiertos inox LP
 - Insertador en forma de embudo LP

TECHNICAL FEATURES

- Structure in double wall in stainless steel, this design allows us to reduce the thermal and acoustic dispersion
- Independent wash and rinse arms in stainless steel, guarantee optimum washing cycle results
- Display with possibility to view wash and rinse temperature and error codes
- Tank, internal parts and printed guides with rounded corners and double stainless steel filters
- UltraRinse rinse system [constant rinse aid] allows us to maintain constant water temperature during the rinsing phase, as well as constant rinse pressure and water flow independent of the water mains conditions
- Peristaltic rinse aid dispenser and detergent, with the possibility to regulate them in the control panel
- Optional:
 - Support 8 trays maximum depth 4cm for LP [measures 50x50cm]
 - Stainless stand 5 trays for LP maximum depth 6,5cm [measures 50x50cm]
 - Stainless steel LP cutlery container
 - LP Funnel Inserter

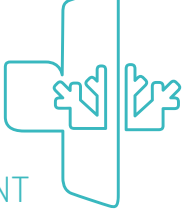

EQUIPAMIENTO COMPLEMENTARIO / COMPLEMENTARY EQUIPMENT



Modelo Model	LP4060	LP6561
Dimensiones [mm] [LxPxA] Dimensions [mm] [WxDxH]	600x700(1135)x1228	719x782(1180)x1727 (1997)
Medidas de cesta [mm] Baskets measures [mm]	500x600	550x610
Altura útil de lavado [mm] Washing useful height [mm]	405 / 380	650 / 600
Ciclos de lavado estándar [Seg.] Standard washing cycles [Seg.]	120-240-360-720-autolimpieza 120-240-360-720-autoclean	120-240-360-720-autolimpieza 120-240-360-720-autoclean
Producción horaria cestas /h Hourly production baskets /h	30	30
Tensión/Frecuencia [V/Hz] Voltage / Frequency [V/Hz]	400/50/3	400/50/3
Potencia máxima funcionamiento [W] Maximum power [W]	6700	7500
Potencia resistencia cuba [W] Tank heater power [W]	2100	3000
Potencia resistencia boiler [W] Boiler heater power [W]	6000	6000
Potencia bomba lavado [W] Pump power [W]	700	1500
Temp. Lavado / Aclarado [°C] Washing / rinsing temp. [°C]	55°C-65°C/80°C-85°C	55°C-65°C/80°C-85°C
Capacidad cuba/boiler [L] Boiler / tank capacity [L]	23/7	37/12
Consumo agua ciclo [L] Water cycle consumption [L]	2,4	3
Dotación Dotation	1 Cesto universal inoxidable 500x600mm 1 Universal stainless steel basket 500x600mm	1 Cesto universal inoxidable 550x610mm 1 Universal stainless steel basket 550x610mm

PHARMA

1

HEALTH

2

LAB

3

4

5

6

7

8



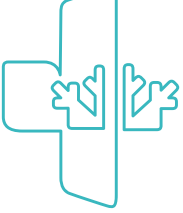

SOLUCIONES A MEDIDA CUSTOMISED SOLUTIONS

¿...Y SI TODO LO QUE LE PROPONEMOS NO FUERA SUFICIENTE?

Infrico Medcare ofrece un servicio de asesoramiento personalizado.

Nuestra oficina técnica está a disposición de sus clientes para que nos expliquen sus proyectos más complejos.

En muchas ocasiones las aplicaciones de nuestros usuarios son muy específicas. Para ello nuestro departamento de I+D atenderá y buscará una solución para cualquier tipo de petición.

¡No duden en contactar con nosotros!

...AND IF EVERYTHING WE PROPOSE YOU WAS NOT SUFFICIENT?

Infrico Medcare offers personalised consulting service.

Our technical office is available to our customers in order to explain to us their most complex projects.

In many cases the applications of our users are very specific. For this purpose, our R&D department will attend and look for any solutions for all kinds of requests.

Do not hesitate to contact us!



PHARMA

1

HEALTH

2

LAB

3

4

5

6

7

8

Cuidamos de tu satisfacción...
We care about your satisfaction...



Servicios Técnicos
Technical services

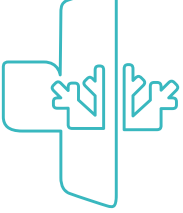

SERVICIO DE ATENCIÓN AL CLIENTE CUSTOMER SERVICE

Infrico Medcare siempre contigo... Infrico Medcare is always with you...

Disponibilidad **Availability**

Asesoramiento **Consulting**

Soluciones **Solutions**

Sabemos perfectamente que las necesidades de tu laboratorio o farmacia exigen una tranquilidad en cuanto al servicio de atención de los equipos adquiridos, su puesta en marcha o validación.

Para contactar con nuestro servicio de atención al cliente:

We are well aware that the needs of your laboratory or pharmacy require a reliable technical service for the equipment purchased, its start-up or validation of its functioning.

Contact our customer service at:

(0034) 957 595 114

info@infricomedcare.com

PHARMA

1

HEALTH

2

LAB

3

4

5

6

7

8



TABLA DE CARACTERÍSTICAS GENERALES / GENERAL FEATURES CHART

CARACTERÍSTICAS / FEATURES	FARMACIA PHARMACY		BANCO DE SANGRE BLOOD BANK	LABORATORIO LABORATORY	
	CARE	PLUS	PLUS	CARE	PLUS
GAMA / SERIES					
Controlador Digital Digital controller	●	○	-	●	-
Controlador Digital plus Digital plus controller	○	●	●	○	●
Tecnología INVERTER INVERTER Technology	-	●	-	-	-
Cerradura Door lock	●	●	●	●	●
Sensor de puerta Door sensor	●	●	●	●	●
Alarmas temperatura Temperature alarm	●	●	●	●	●
Alarma puerta abierta visual y acustica Visual and acoustic open door alarm	●	●	●	●	●
Historico de alarmas Alarm history	○	●	●	○	●
Señal de alarma remota [contacto libre de potencial] Remote transmission alarm signal [via potential-free contact]	●	●	●	●	●
Termostato de seguridad anticongelación Antifreeze safety thermostat	●	●	●	○	○
Desescarche automático Automatic defrost	●	●	●	●	●
Interior Acero Inox Stainless steel Interior	○	○	●	○	○
Exterior Acero Inox Stainless steel Exterior	○	○	○	○	○
Luz LED LED lighting	●	●	●	●	●
Batería Battery	●	●	●	○	●
Ruedas Casters	○	○	○	○	○
RS485 Puerto de comunicación Modbus RS485 Modbus communication port	○	●	●	-	●
Sensor temperatura ambiente Interior room temperature sensor	○	●	●	○	●
Salida USB USB port	-	●	●	-	●
Datalogger Datalogger	○	●	●	○	●
Sonda simulación de producto Product temperature simulation probe	○	○	●	○	○
Otros tipos de clavija Other plugs types	○	○	○	○	○

- ESTANDAR / STANDARD
- OPCIONAL / OPTIONAL
- NO DISPONIBLE / NOT AVAILABLE



TABLA DE SELECCIÓN DE PRODUCTO / PRODUCT SELECTION CHART

APLICACIÓN APPLICATION	PRODUCTO PRODUCT	GAMA SERIES	70 L	110 L	150 L	170 L	250 L	300 L	360 L	400 L	430 L	500 L	600 L	650 L	700 L	900 L	1300 L	1400 L	TEMPERATURA TEMPERATURE
FARMACIA PHARMACY	REFRIGERADOR REFRIGERATOR	CARE	●		●				●										+2°C / +8°C
		PLUS				●	●	●		●		●		●		●	●		
BANCO DE SANGRE BLOOD BANK	REFRIGERADOR REFRIGERATOR	PLUS				●	●			●						●		●	+4°C
LABORATORIO LABORATORY	REFRIGERADOR REFRIGERATOR	CARE	●		●	●	●		●	●		●		●		●	●		+2°C / +8°C
	ARMARIO DE CONGELACIÓN FREEZER	CARE			●		●			●	●		●	●		●	●		-10°C / -25°C
		PLUS					●			●		●		●	●				-20°C / -40°C
	MIXTO DUAL TEMP	CARE															●		+2°C / +8°C -10°C / -25°C
	ULTRA CONGELADOR ULTRAFREEZER	PLUS		●						●		●				●	●		-40°C / -86°C
	ARCÓN ULTRA CONGELADOR CHEST ULTRAFREEZER	PLUS										●				●			-40°C / -86°C



- PHARMA
- 1
- HEALTH
- 2
- LAB
- 3
- 4
- 5
- 6
- 7
- 8

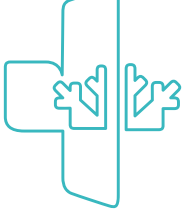
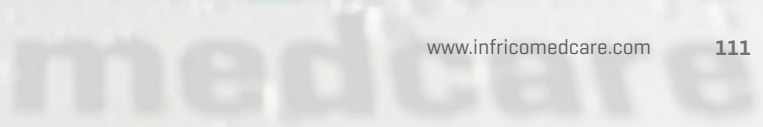



We care about your success...

Para la realización de este catálogo, hemos puesto el mayor cuidado en describir nuestro producto lo mejor posible. No obstante, continuamente estamos trabajando en la evolución de todas las gamas disponibles, por lo que aconsejamos consultarnos todas las dudas que pudieran tener. Asimismo, les pedimos su comprensión puesto que el diseño y todos los datos técnicos, ilustraciones e información están sujetos a cambios.

For the development of this catalogue, we have taken the utmost care in describing our product as best as possible. However, we are continually working on the evolution of all available series. So please do not hesitate to ask us any questions you may have. Therefore, we kindly request that you take into account, that design and technical data, illustrations and information are all subject to change.



Crtra. de Aguilar a A-318 por Moriles, Km 15.5, A-3132

14900 Lucena [Córdoba] Spain

Telf.: 0034 957 59 51 14

Fax: 0034 957 59 11 83

info@infricomedcare.com

www.infricomedcare.com

